



**A CARTER GROUP COMPANY**

15A Rovon Place, Bairnsdale, VIC, 3875

[www.cartercranes.com](http://www.cartercranes.com)

[info@cartercranes.com](mailto:info@cartercranes.com)

0429 833 475

CRANE SPECIFICATION

# ZOOMLION ZTC300V5

Heavy-duty crane hire and specialised haulage, backed by experience operators and reliable service.

Contact us to discuss your lifting requirements and a free quote.



# TELESCOPIC CRAWLER CRANE OPERATOR'S MANUAL

Zoomlion Heavy Industry Science & Technology Co.,Ltd.





# **ZOOMLION**

## **ZCT300V532-1**

### **Telescopic Crawler Crane**

### **Operator's Manual**

Edition 1    October 2022



## To Users

Zoomlion appreciates your selection of ZOOMLION telescopic crawler crane for your application.

No one should operate the crane unless they read and understand the information in this manual.

This manual contains the instructions and data on the safety and operation of the telescopic crawler crane. Follow the operation procedures to make sure that your machine operates at **MAXIMUM EFFICIENCY**. The operator must keep this manual in the cab of the crane.

If there is anything in the manual that is not clear or you do not understand, please contact our service technician. We (Zoomlion) are **NOT** responsible for damages from an operator who does not obey the instructions in the *OPERATOR'S MANUAL*.

The *OPERATOR'S MANUAL* is an important part of the crane. If the crane becomes the property of a different person, make sure that the manual stays in the cab of the crane.

The data (data, specifications, illustrations) in this manual is for cranes in production at the time of this manual's publication. We reserve the right to make changes to this manual at any time, without obligation.

The manual has been translated to be best of our knowledge. Zoomlion assumes no liability for translation errors. The Chinese version of the *OPERATOR'S MANUAL* is solely applicable for factual accuracy.

Thank you!

Mobile Crane Branch Company of Zoomlion Heavy Industry Science and Technology Co., Ltd.

### Copyright

Under the copyright laws, this manual may not be copied, photocopied, reproduced, translated, or reduced to any electronic medium or machine readable form, in whole or part, without the prior written consent of Zoomlion Heavy Industry Science and Technology Co., Ltd.

Copyright © 2021, Zoomlion Heavy Industry Science and Technology Co., Ltd.

All rights reserved.

## Safety Instructions

The following terms that are used in these operating instructions "Danger", "Warning", "Caution" and "Notice" are intended to point out certain important rules of conduct to all persons who work with the crane. The meanings of the terms are as follows:



Refers to a dangerous situation which, if you do not prevent, will cause death or injury.



Refers to a possible dangerous situation which, if you do not prevent, could cause death or injury.



Refers to a possible dangerous situation which, if you do not prevent, may cause light or moderate injury.

NOTICE

Refers to a tip or hint in the operation instructions.

**CONTENTS**

<b>To Users</b> .....	I
<b>Safety Instructions</b> .....	II
<b>Chapter 1 Safety</b>	
1.1 Foreword .....	1-1
1.2 Safety instructions .....	1-3
1.2.1 Note .....	1-3
1.2.2 Alarms and warnings .....	1-3
1.2.3 Component safety features .....	1-3
1.3 Environmental safety .....	1-4
1.4 Personal protective equipment (PPE) .....	1-4
1.5 Measured noise level.....	1-4
1.6 Vibration levels .....	1-4
1.7 Organizational safety measures.....	1-5
1.8 Personnel qualification, requirements and responsibilities .....	1-5
1.9 Safety advice regarding specific operational phases .....	1-5
1.9.1 Standard operation .....	1-5
1.9.2 Malfunction .....	1-6
1.9.3 Unguarded areas.....	1-6
1.10 Special Hazards.....	1-6
1.10.1 Electrical energy .....	1-6
1.10.2 Gas, dust, steam, smoke and noise .....	1-7
1.10.3 Welding or naked flames .....	1-7
1.10.4 Hydraulic equipment.....	1-7
<b>Chapter 2 Description of Crane</b>	
2.1 PRODUCT MODEL .....	2-1
2.1.1 Product name plate and its position .....	2-1
2.1.2 Engine type and its manufacturer.....	2-1
2.1.3 Intended use of the crane.....	2-1
2.1.4 Crane design calculation .....	2-2
2.2 TERMINOLOGY .....	2-3
2.3 PRODUCT DESCRIPTION .....	2-4
2.3.1 Crane engine .....	2-4

2.3.2	Boom and telescoping mechanism .....	2-4
2.3.3	Jib .....	2-5
2.3.4	Hydraulic system .....	2-5
2.3.5	Electrical system.....	2-5
2.3.6	Hoisting winches.....	2-5
2.3.7	Derricking system .....	2-6
2.3.8	Slewing mechanism .....	2-6
2.3.9	Counterweight .....	2-6
2.3.10	Operator's cab.....	2-6
2.3.11	Crane undercarriage.....	2-7
2.3.12	Safety devices .....	2-8
2.4	TECHNICAL DATA .....	2-10
2.4.1	Overall dimensions .....	2-10
2.4.2	Main technical parameters .....	2-11
2.5	LIFTING PERFORMANCE .....	2-13
2.5.1	Working radius.....	2-13
2.5.2	Rated capacity charts .....	2-14

### **Chapter 3 Safety Guidelines**

3.1	Operational planning .....	3-1
3.1.1	Lifting performance of the crane.....	3-2
3.1.2	Appropriate use .....	3-2
3.1.3	Examples of inappropriate use.....	3-2
3.1.4	Areas of responsibility .....	3-3
3.1.5	Work area .....	3-4
3.2	Safety technical notes .....	3-5
3.2.1	Safety instructions .....	3-5
3.2.2	Points for attention for crane operating crew .....	3-8
3.2.3	Points for attention during crane operation .....	3-9
3.3	Requirements for operating site .....	3-10
3.3.1	Selecting an operating site .....	3-10
3.3.2	Slopes and trenches.....	3-10
3.3.3	Permissible ground pressure.....	3-11
3.3.4	Checking safety measures .....	3-12
3.4	Working weather.....	3-13
3.5	Electromagnetic influences .....	3-13
3.6	Underground cables .....	3-15
3.7	Checking safety measures .....	3-18
3.8	Crane operation with a load .....	3-18

3.8.1	Operating conditions .....	3-18
3.8.2	Instructions for safety operation .....	3-20
3.8.3	Preparation and checks for crane operation .....	3-23
3.9	Safety signs .....	3-27
3.9.1	Safety signs on the operator's cab .....	3-27
3.9.2	Safety signs on the slewing table .....	3-30
3.9.3	Safety signs on the undercarriage.....	3-31
3.10	Hand signals for controlling crane operations .....	3-33

## **Chapter 4 Crane Operation**

4.1	OPERATING AND CONTROL INSTRUMENTS .....	4-1
4.1.1	Operator's cab overview.....	4-1
4.1.2	Upper control panel .....	4-3
4.1.3	Right control panel.....	4-4
4.1.4	Left and right joysticks .....	4-5
4.1.5	Left control panel .....	4-6
4.2	COMPUTER SYSTEM .....	4-8
4.3	ADJUSTMENT OF CRANE OPERATOR'S SEAT .....	4-10
4.4	STARTUP OF THE CRANE .....	4-13
4.4.1	Check the general conditions of the crane before startup.....	4-13
4.4.2	Turn on power supply .....	4-14
4.4.3	Air conditioner.....	4-15
4.4.4	Checks before engine start .....	4-16
4.4.5	Start the engine .....	4-18
4.5	SAFETY DEVICES .....	4-21
4.5.1	Emergency stop button .....	4-21
4.5.2	Battery master switch .....	4-21
4.5.3	Power supply indicator light.....	4-22
4.5.4	Lowering limit switch .....	4-22
4.6	CRANE OPERATION .....	4-24
4.6.1	Requirements before operation .....	4-24
4.6.2	Checks during crane operation .....	4-24
4.6.3	Setting of boom configuration.....	4-24
4.6.4	Operation of travel gear.....	4-25
4.6.5	Telescoping operation .....	4-27
4.6.6	Derricking operation .....	4-29
4.6.7	Lifting and lowering operation .....	4-30
4.6.8	Slewing operation .....	4-35
4.6.9	Free swing operation.....	4-37

4.6.10 Crawler carrier extending .....	4-38
4.7 CHANGE OF REEVING .....	4-40

## **Chapter 5 Assembly and Dismantling**

5.1 Safety-technical notes .....	5-1
5.1.1 Notes on assembly .....	5-1
5.1.2 Checking safety measures .....	5-1
5.1.3 Inspection of wire rope, hook and rope pulley .....	5-2
5.2 Assembly of basic machine .....	5-4
5.2.1 Transportation modes .....	5-4
5.2.2 Loading of crane body .....	5-4
5.2.3 Unloading of crane body .....	5-5
5.2.4 Jib installation .....	5-7
5.2.5 Rooster sheave .....	5-14
5.2.6 Assembly of crawler carriers .....	5-16
5.3 Transport means and requirements for transportation and storage .....	5-17
5.3.1 Transport means and requirements for transportation .....	5-17
5.3.2 Requirements for storage .....	5-17

# **ZOOMLION**

## **Operator's Manual for Telescopic Boom Crawler Crane**

### **Chapter 1 Safety**





## Chapter 1 Safety

### 1.1 Foreword

The operator's manual is intended to put you in a position to operate the crane safely and utilize its capabilities to the fullest extent.

Some of the terms used in this manual have been clarified. In order to avoid misunderstandings in the operation, it is necessary to have a correct understanding of these terms.

#### DANGER

- (1) Only qualified and especially trained personnel are permitted to work on the crane!**
- (2) If operators are not trained, the possibility of causing serious accidents will greatly increase. Operators should not work on their posts without training.**

All rules and guidelines applicable to the site, such as provisions for the accident prevention, have been described in detail in this operator's manual. This must be strictly observed.

All operational guidelines for the accident prevention are applicable to the use of cranes for lifting and transporting the loads as required. Any other application or use does not constitute specified and proper use.

Any risks associated with unspecified and improper use are the sole responsibility of the crane's owner, operator or user.

#### CAUTION





- (1) Using these instructions in the manual makes you easier to become familiar with the crane.**
- (2) Using these instructions in the manual avoids malfunctions due to improper operation.**
- (3) Observing these instructions in the manual increases reliability in operations.**
- (4) Observing these instructions in the manual extends the service life of the crane.**
- (5) Observing these instructions in the manual reduces repair costs and downtime.**

Always keep the operator's manual handy in crane operator's cab - it is an integral part of the crane. Operate this crane if you are well familiarized with the capabilities and limitations of the crane, and always follow these operating instructions.

If you have received additional information about the crane from us, e.g. in the form of technical information letters, then this information must also be followed and kept with the operator's manual.

If there is anything in the operator's manual or the individual chapters that you do not understand, please do not hesitate to ask us or our distributors before you begin operation.

The operator's manual must be read and the regulations in it must be observed by all persons operating, maintaining, or otherwise working on this crane.

The content with respect to safety is marked with  "WARNING",  "DANGER",  "CAUTION" and  "NOTICE". And the safety instructions involved in the manual are only the conventional contents. The meaning of these safety technologies please refer to "Safety Information".

### CAUTION

**Normally, do not weld on the crane. In special cases, when welding work is conducted on the crane, the operator should unplug all power source plugs of controllers and cut off the master power, otherwise, he should take all consequences incurred.**

### DANGER

**The safety devices built into the crane system deserve your special attention. They must always be checked to see that they are functioning properly. If they do not function or function incorrectly, the crane may not be operated. Your motto must always be Safety First.**

## 1.2 Safety instructions

### 1.2.1 Note

- a) Read this manual and familiarize yourself with any associated documents before operating this crane.
- b) Ensure that a copy of this manual is available for any persons installing, using, or maintaining this crane.
- c) Training should be provided to ensure safe working practices.
- d) To avoid the risk of electric shock always isolate this crane from the power supply prior to carrying out any maintenance work or removing any guards or covers.
- e) If in doubt, do not take personal risk.
- f) Only trained personal can be allowed to install, operate, maintain, and commission this crane.

### 1.2.2 Alarms and warnings

- a) Any residual risks identified within this manual are to be marked in an appropriate position of the crane. Ensure these warnings are maintained.
- b) To ensure personnel safety, please observe all the safety instructions.
- c) Ensure that safety instructions and warnings attached to the working area are always complete and perfectly legible.
- d) Keep warnings and instruction labels clean.
- e) Replace unreadable or missing labels with new ones before operating the crane. Make sure replacement parts include warnings or instruction labels where necessary.



- (1) To assure personnel safety, please observe all the above warnings.**
- (2) For the position of warnings and instruction labels, please see section 3.9.**

### 1.2.3 Component safety features

- a) Do not use this crane with guards removed or incorrectly fastened.
- b) Do not use this crane with safety devices maladjusted or removed.
- c) Safety component – crane emergency stop button. Ensure the button is functional, please see section 4.5.1.
- d) Steps, handrails, tread plates and fixed guards are provided to assist the personnel to climb on the crane.

### 1.3 Environmental safety

- a) A regular service should be taken on the crane strictly in accordance with maintenance procedures to ensure that engine emission is close to a minimum value.
- b) Diesel spillages must be dealt with immediately to avoid fire hazard and pollution.
- c) Only use the lubricating oil recommended in the maintenance manual.
- d) Local and national regulations must be observed when disposing of waste.
- e) Potentially harmful waste used on this crane includes such items as hydraulic oil, fuel, lubricant, coolant, filters and batteries, etc.
- f) Use leak-proof containers for draining fluids. Do not use food or beverage containers that may mislead someone into drinking from them.
- g) Do not pour waste into the ground, down a drain or into any water source.
- h) Ensure that all consumables and replaced parts are disposed of safely and with minimum environmental impact.
- i) Machine disposal. This machine must only be disposed of by a specialized machine breaker.

### 1.4 Personal protective equipment (PPE)

- a) Loose or baggy clothing can get caught in running machinery.
- b) Where possible when working close to engines or machinery, only do so when they are stopped. If this is not practical, remember to keep tools, test equipment and all other parts of your body well away from the moving parts.
- c) For reasons of safety, long hair must be tied back or otherwise secured, garments must be close to your body and no jeweler such as rings may be worn.
- d) Correctly wear personal protective equipment.
- e) Protective equipment for recommended personnel includes: hard hat, safety glasses / goggles, hearing protection, close fitting overalls, safety boots, industrial gloves, high visibility vest or jacket.

### 1.5 Measured noise level

The condition of working site may affect the noise levels.

The measured sound pressure level and sound power level (LP(A) and LW(A)) are respectively 78.5dB (A) and 110.5dB (A). The stationary sound level is 77.8dB (A).

### 1.6 Vibration levels

Suitable support has been installed to reduce the risk of whole body vibrations, in line with current industry standards.

## 1.7 Organizational safety measures

- a) The crane must only be operated by a suitably qualified operator who holds a current license in line with National / International legislation in the operating area.
- b) Understand the service procedure before doing work. Keep the area clean and dry.
- c) Never lubricate, clean, or adjust the crane while it is operating.
- d) Keep hands, feet and clothing clear of power driven parts and running nip-points.
- e) Keep all parts in good condition. Ensure that all parts are properly installed. Fix damage immediately. Replace worn and broken parts. Remove any build-up of grease, oil and debris.
- f) Disconnect battery ground cable and power supply before making adjustments on electrical systems.
- g) Disconnect battery ground cable and power supply and unplug all plugs of controllers before welding on crane.
- h) During maintenance only use the correct tool for the job.
- i) Never make any modifications, additions or conversions which might affect safety without the manufacturer's approval.
- j) In the event of safety relevant modifications or changes in the behavior of the crane during operation, stop the crane and lock it out immediately and report the malfunction to the competent department / person.

## 1.8 Personnel qualification, requirements and responsibilities

- a) Any work on the crane must be executed by trained, reliable and authorized personnel only.
- b) Maintenance work must only be undertaken by suitable qualified engineers with specialist knowledge of this crane.
- c) Work on the hydraulic system must be carried out only by personnel with special knowledge and experience of hydraulic equipment.
- d) Work on the electrical system must be carried out only by personnel with special knowledge and experience of electrical equipment.

## 1.9 Safety advice regarding specific operational phases

### 1.9.1 Standard operation

- a) Take necessary precautions to ensure that the crane is used only when it is in a safe and reliable state.
- b) This crane is a conventional lifting and assembly machine. Do not apply the crane for other purpose.

- c) Operate the crane only for its designed purpose and only if all guarding, protective and safety orientated devices, emergency shut-off equipment, sound proofing elements, are in place and fully functional.
- d) Ensure that any local barriers erected to stop unauthorized entry to this crane are in place.
- e) Before starting the engine ensures it is safe to do so.
- f) No person is allowed to stay under the boom and within the slewing area.

### **1.9.2 Malfunction**

In the event of any malfunction or operational difficulty, stop the crane immediately.

### **1.9.3 Unguarded areas**

- a) In-running nip points on moving crane can cause serious injury or even death.
- b) Do not reach into unguarded crane. Your arm, hair and sleeve could be pulled in and amputated.
- c) Stop the crane before removing any safety devices.
- d) Limit access to the crane and its surrounding where barrier guards are appropriately erected to reduce the risk of mechanical hazards, such as falling lifted loads.

## **1.10 Special Hazards**

### **1.10.1 Electrical energy**

#### **1.10.1.1 External considerations and hazards**

When working with the crane, maintain a safe distance from the overhead electric lines. If overhead lines are in the immediate vicinity, a risk assessment must be completed prior to operating this crane.

If your crane comes into contact with a live wire:

- a) Vacate the area.
- b) Warn others against approaching and touching the crane.
- c) Report the incident and have the live wire de-energized.

#### **1.10.1.2 Electrical system**

- a) The electrical equipment of the crane must be inspected at regular intervals. Defects such as loose connections or scorched or otherwise damaged cables must be rectified immediately.
- b) Use only original fuses with the specified current rating.
- c) Switch off the crane immediately if trouble occurs in the electrical system.
- d) This crane is wired on a negative earth. Always observe correct polarity.

### 1.10.1.3 Battery

- a) Always disconnect battery leads before carrying out any maintenance to the electrical system.
- b) Charge the battery in a well-ventilated area.
- c) The battery contains sulphuric acid, an electrolyte which can cause severe burns and produce explosive gases. Avoid contact with the skin, eyes or clothing.
- d) No smoking when maintaining battery.
- e) Wear appropriate PPE.

### 1.10.2 Gas, dust, steam, smoke and noise

- a) Always operate the engine out of doors or in a well-ventilated area.
- b) If crane is operated for maintenance purposes in an enclosed area, ensure that there is sufficient ventilation or provide forced ventilation.
- c) Observe the rules and regulations at different working site.
- d) Dust found on the crane or produced during work on the crane must not be removed by blowing with compressed air.
- e) Toxic dust / waste must only be dampened by authorized persons, and then placed in a sealed container and marked, to ensure safe disposal.

### 1.10.3 Welding or naked flames

- a) Welding, flame cutting and grinding work on the crane must only be carried out if this has been expressly authorized, as there may be a risk of explosion and fire.
- b) It is prohibited to carry out welding work that will affect crane structural integrity.
- c) Avoid all naked flames in the vicinity of this crane.

### 1.10.4 Hydraulic equipment

- a) Work on hydraulic system must be carried out by persons having special knowledge and experience of hydraulic system.
- b) Check all lines, hoses and screwed connections regularly for leaks and obvious damage. Repair damage immediately. Sprayed oil may cause personal injury.
- c) Depressurize hydraulic system before carrying out any maintenance work.
- d) Hydraulic lines and compressed air lines must be laid and fitted properly. The fittings, lengths and quality of the hoses must comply with the technical requirements.
- e) Only fit replacement components of a type provided by the manufacturer.
- f) Always keep the hydraulic components clean.
- g) Hydraulic fluid under pressure can penetrate the skin causing serious injury. Once the fluid is injected under the skin, seek medical help immediately.



# **ZOOMLION**

## **Operator's Manual for Telescopic Crawler Crane**

### **Chapter 2 Description of Crane**





## Chapter 2 Description of Crane

### 2.1 Product model

#### 2.1.1 Product name plate and its position

The product name plate and its position are shown in the figure 2-1.

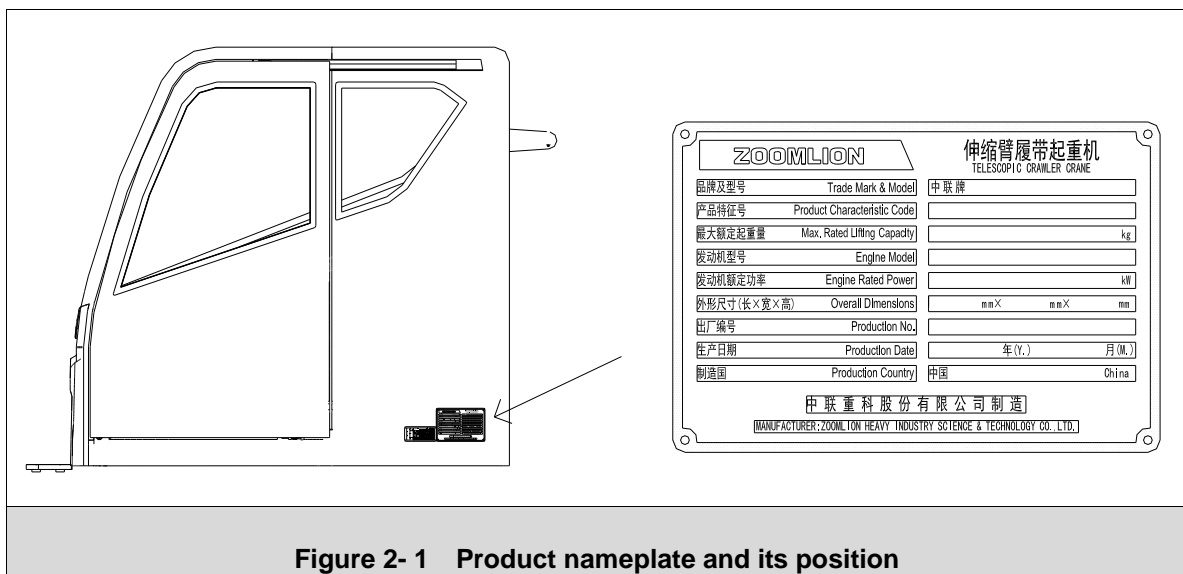

Figure 2- 1 Product nameplate and its position



- (1) Please provide the information in the name plate when requesting Zoomlion service.
- (2) The Serial No. and Year of manufacture shown on the product nameplate must be given by machine manufacturer before delivery.

#### 2.1.2 Engine type and its manufacturer

Engine type: Weichai WP6G190E301 (Emission: Chinese National Stage III);

Engine manufacturer: Weichai Power Co., Ltd.

#### 2.1.3 Intended use of the crane

This telescopic crawler crane is designed for lifting load.

It is prohibited to transport people with this crane! In many cases, there have been serious injuries when people have been transported using this crane (or even on the hook or on loads). Under such circumstances, they have no control over the crane movements and are not protected against bumps or falls. Even the smallest error can cause vital injury! In exceptional cases, please consult the responsible authorities concerning safety regulations.

It is expressly forbidden to use the crane for jumps with rubber ropes (bungee jumping)! Using the crane for such jumps represents a misuse of the crane and entails extreme danger for life and limb!

The crane is designed exclusively for assembly and lifting operation, i.e. lifting loads, non-continuous use of the crane. Any other type of use or otherwise use which goes beyond its limits specified, such as handling of general cargo or grab operation, are not classified as intended use. The manufacturer shall not be liable for any damage caused. The operator bears full responsibility for this type of misuse.

The use of two hoisting winches for lifting loads (twin hook operation) is only permitted following consultation from the crane manufacturer.

The intended use also includes the observation of *Lifting Capacity Chart*, *Operator's Manual* and *Maintenance Manual*.

## 2.1.4 Crane design calculation

### 2.1.4.1 General

The crane has been constructed using state of the art technology and in accordance with recognized safety regulations. Nevertheless, its use can lead to hazards for the life and limb of the operator and third parties, and/or damage to the machine and other objects.

Use the crane only when it is in full working order and only for its intended use, paying attention at all times to safety and potential hazards, and in observance of the *Operator's Manual* and *Maintenance Manual*.



**Have any malfunctions which might impair safety rectified immediately.**

### 2.1.4.2 Classification of the crane

The crane is classified as follows in accordance with ISO 4301-2, GB/T 3811 and GB/T 14560 standards.

All important components of the crane are designed and manufactured for normal assembly operation. Operating conditions or types of use other than assembly operation require the permission of the manufacturer and normally lead to a reduction in the lifting capacities.

## 2.2 Terminology

To assist in understanding of this manual, the following terminologies are introduced.

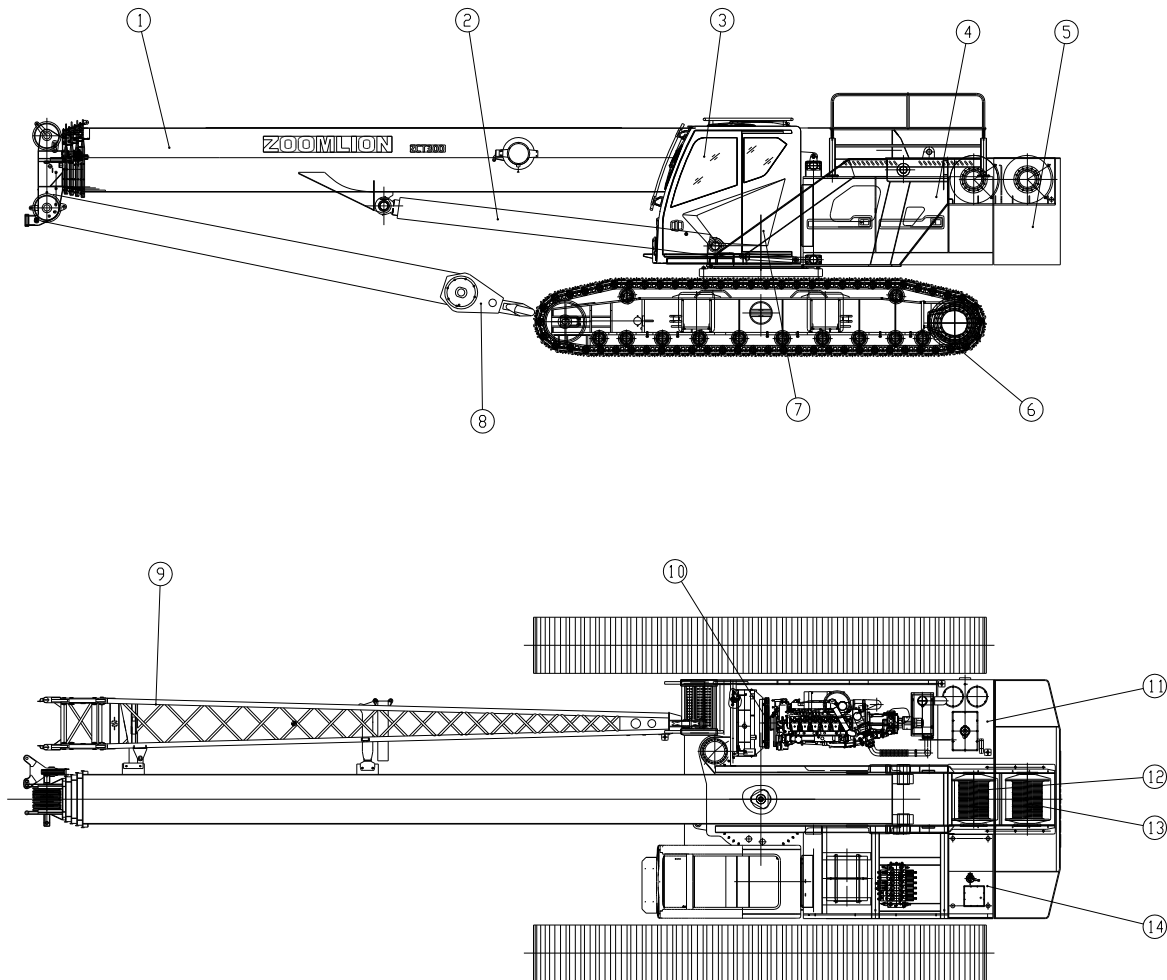

**Figure 2-2 Main components**

**Table 2- 1 Introduction of main components**

No.	Description	No.	Description
1	Boom assy.	8	Hook
2	Derricking cylinder	9	Jib (optional)
3	Driver's cab assy. (with optional cab tilting mechanism)	10	Engine assy.
4	Hood assy. (with optional guard rail)	11	Hydraulic oil tank
5	Counterweight	12	Auxiliary winch
6	Undercarriage	13	Main winch
7	Slewing platform	14	Fuel tank

## 2.3 Product description

### 2.3.1 Crane engine

Engine model: Weichai WP6G190E301

Type: six-cylinder in-line, intercooling turbine diesel engine

Displacement: 6.75L

Rated power: 140 kW/2000rpm

Max. torque: 860 N·m/1500rpm

Fuel tank capacity: 400L



**When the crane is working at an altitude of 2500 meters or less, the rated output power of engine will not decrease. While the crane is working at an altitude of more than 2500 meters, the rated output power of engine will decrease. For details, please consult local engine service department.**

### 2.3.2 Boom and telescoping mechanism

The box-shaped boom consists of 5 U-type boom sections made of low-alloy high-strength steel plate, providing the boom with excellent bending-resistance capacity, super load bearing capacity, light deadweight, large lateral stiffness and low end deflection.

The boom adopts an independently designed structure of imbedded sliding block, contributing to a larger connecting ratio between boom sections. A series of optimized design have the deadweight of the boom greatly decreased and the stress on the boom evenly distributed to avoid partial distortion. Furthermore, the boom has good guidance quality and adjustability. Optimized plate-type structure of boom head (except of the top boom section) is adopted, which efficiently increases the overlapping length between adjacent boom sections and achieves a minimum length of the basic boom section.

The telescopic boom sections are telescoped in / out via two telescoping cylinders and two sets of boom extension / retraction rope. The telescoping cylinder I drives the telescopic boom section 2 to telescope in / out, while the telescoping cylinder II drives the telescopic boom section 3. The boom section 4 and 5 are telescoped in / out simultaneously together with the boom extension / retraction rope. This compact design makes the crane work reliably. Each cylinder is fitted with a balance valve.

### 2.3.3 Jib

The 8 m jib is consisted of one jib section of a square lattice structure. Its variable cross-section structure contributes to its superior bearing performance. The jib is installed through pins onto one side of the boom when not being used.

The jib section is hinged to the head of the top boom section through pins. The jib can be installed at one of the three angles onto the boom, i.e. 0°, 15° and 30°. Change of the angles is realized conveniently through a rotary shaft and sliding groove.

### 2.3.4 Hydraulic system

The hydraulic pilot proportionally controlled system realizes movements of executing mechanisms through the planetary reducer driven by a high-speed hydraulic motor. The system is characterized in its advantages e.g. high efficiency, energy-saving, smooth and safe compound movements, high level of safety and reliability.

Hydraulic oil tank capacity: 600L.

### 2.3.5 Electrical system

24 Volt DC, negative grounded, two batteries of 200AH each

The electrical system of the crane includes the power supply, engine start, engine shutdown, indicator light, warning device, illumination device, fan, wiper, horn, hoisting limiter, concentrated display panel, load moment limiter, safety devices etc. which not only ensure safe operation of the crane, but also provide a good working environment.

### 2.3.6 Hoisting winches

It consists of a main hoist mechanism and an auxiliary hoist mechanism. The two hoist mechanisms are driven by an axial plunger hydraulic motor with a built-in planetary gear reducer to lift or lower the hook. A brake is fitted between the motor and reducer. The two winch mechanisms can be controlled independently and also can carry out compound movements.

The auxiliary hoist winch is of same model of the main winch, and both of them adopt a variable motor. The main winch is installed with a lowering limit switch which gives alarm when there are only 3 wraps of wire rope left on the drum. The sealed-in planetary reducer is of a compact structure, light deadweight and high reliability.

Specifications for high-tensile torsion resistant hoist rope:

Diameter:  $\phi 17.0$  mm

Strength grade: 1870 N/mm<sup>2</sup>

Length of main hoist rope: 180 m

Length of auxiliary hoist rope: 110 m

Pulling force of single wire rope: 4 t.

### 2.3.7 Derricking system

Front-mounted derricking mechanism installed with a single cylinder, capable of derricking the boom within  $-1.5^{\circ}$  -  $80^{\circ}$ . A balance valve is installed in the oil cylinder, ensuring stable derricking operations.

### 2.3.8 Slewing mechanism

The slewing mechanism is installed with two reducers and two slewing motors. The hydraulic motor drives the slewing mechanism via a planetary reducer. The pinion gear on reducer output shaft rotates around the slewing ring on the undercarriage central section, thus achieving  $360^{\circ}$  continuous rotation of the slewing table.

The free-swing function can automatically align the boom with the center of a load. A slewing cushion valve and a normally-closed brake are installed, ensuring stable and reliable slewing operation. The four-point ball type slewing bearing realizes strong bearing performance and long service life.

### 2.3.9 Counterweight

Fixed counterweight, 12.5 t in total.

### 2.3.10 Operator's cab

The spacious and full-closed cab is equipped with safety glass, adjustable seat, intermittent wiper and window water injector. Soft interiors cover the whole internal space of the cab. A cab tilting mechanism is optional.

#### ☛ Control boxes

The control boxes on both side of the cab are installed with various electrical switches, etc. They can be adjusted with the operator's seat.

#### ☛ Control levers and travel gear pedals with hand levers

Two hydraulic joysticks, both control main valves through pilot oil.

The left joystick controls slewing and the auxiliary winch, while the right joystick controls derricking (and telescoping) and the main winch.

Telescoping is realized through cylinder I or II, which is switched over by a pre-selection switch.

Two travel gear pedals with hand levers: control telescoping and leftward/rightward traveling movements.

Compound movements are possible through simultaneous movements of joysticks and pedals.

✧ Air conditioner

Standard heating and cooling air conditioner, with optimized air duct and air outlet.

### 2.3.11 Crane undercarriage

✧ Traveling power

Both left and right crawler carriers are fitted with an independent hydraulic driving system. Each hydraulic driving system has a hydraulic motor, which can drive the drive sprocket via a planet reducer.

The operator can use hand levers or travel gear pedals to control the traveling movements, such as traveling straight ahead / backwards, turning with a crawler, differential steering and turning on spot.

When the two crawlers are turning together, it is prohibited to engage in a high speed position. During turning with one crawler or turning on spot with two crawlers, it is recommended to engage in a low speed position to avoid insufficient turning power, as well as component damage due to pressure impact.

✧ Traveling brake

The travel brake is applied via the spring on the traveling motor, which is controlled by a balance valve.

✧ Crawler carrier extending & retracting mechanism

Crawler carriers are extended and retracted via two hydraulic cylinders.

- Crawler carrier extended:

Distance between track centers: 3840mm

- Crawler carrier retracted:

Distance between track centers: 2290mm

✧ Track roller

Maintenance-free, sealed structure

✧ Track pad

High-strength alloy cast steel track pad, its width: 700mm.

✧ Traveling speed

The maximum traveling speed is 2.5 km/h.

### 2.3.12 Safety devices

Many safety devices, mechanical, electronic or hydraulic ones, are fitted on the crane to ensure safe operation of crane.

#### ✧ Load moment limiter

The load moment limiter can automatically detect boom angle and lifting load, and provide feedback of these data to the operator according to the actual lifting situation.

When the normal operating range of the crane is exceeded, the load moment limiter will send out an alarm and limit the current movement.

The color LCD screen can show the following data: moment ratio, boom angle, boom length, working radius, actual load, and rated lifting capacity, etc.

#### ✧ Hoisting limit switch

A device to prevent the hook from exceeding its upper limit position.

If the load hook comes into contact with hoisting limit switch weight during its upward movement, the hoisting limit switch will be triggered, the buzzer will sound, the warning light on the screen will flash and the crane movement "lift the load" will be switched off.

#### ✧ Lowering limit switch

When there are only three wraps of wire rope left on the winch drum, the lowering limit switch will be triggered, the buzzer will sound, the warning light on the screen will flash and the crane movement "reel off" will be switched off.

#### ✧ Slewing locking device

A mechanical and electrical locking device, generally used to fix the relative position between the crane superstructure and undercarriage during transportation so as to avoid accidental operation.

#### ✧ Safety catch

A device used to protect the lifted load from jumping out from the hook

#### ✧ Rear-view mirror

Located in the left front of the cab.

#### ✧ Overflow valves in hydraulic system

The overflow valves fitted in hydraulic system can restrain the pressure in the oil circuit from rising irregularly, thus protecting such hydraulic elements as a hydraulic oil pump and hydraulic motor against damage and preventing the hydraulic system from being overloaded.

#### ✧ Emergency stop button

Allows the engine to be shut down and all movements to be stopped in an emergency situation.

#### ✧ Tricolor warning light

The warning light, by illuminating in red, yellow or green color, can indicate different loading statuses:

Green color – the load ratio is less than 90%

Yellow color – the load ratio is between 90% and 100%

Red color – the load ratio has exceeded 100% and the crane is overloaded.

✦ Anemometer (optional)

An electronic wind speed sensor to indicate actual wind speed at boom/jib head to the crane operator.

✦ Slewing alarm (optional)

An acoustic alarm will be triggered during slewing movements.

✦ Traveling alarm (optional)

An acoustic alarm will be triggered during traveling movements.

✦ Video monitoring system (with optional rear-view camera)

A video display for monitoring the winches and the right side working area is installed as a standard configuration. It monitors the working condition of crane hoisting winches and the blind spots at right side of the crane.

 **CAUTION**

- (1) The crane classification group is A1, and the classification group of working mechanisms is respectively: travel gear (M1), slewing mechanism (M2), hoisting winches (M3) and derricking winch (M2).
- (2) The crane is designed to be a hook crane rather than a grabbing crane, a magnet crane, a shovel crane or a powerful hammer.

### 2.4 Technical data

#### 2.4.1 Overall dimensions

The overall dimensions of this telescopic crawler crane are shown in the figure 2-3. The optional functions and mechanism include: high pressure alarm, anemometer, rear view camera, low temperature start device, guard rail, jib, and cab tilting mechanism.

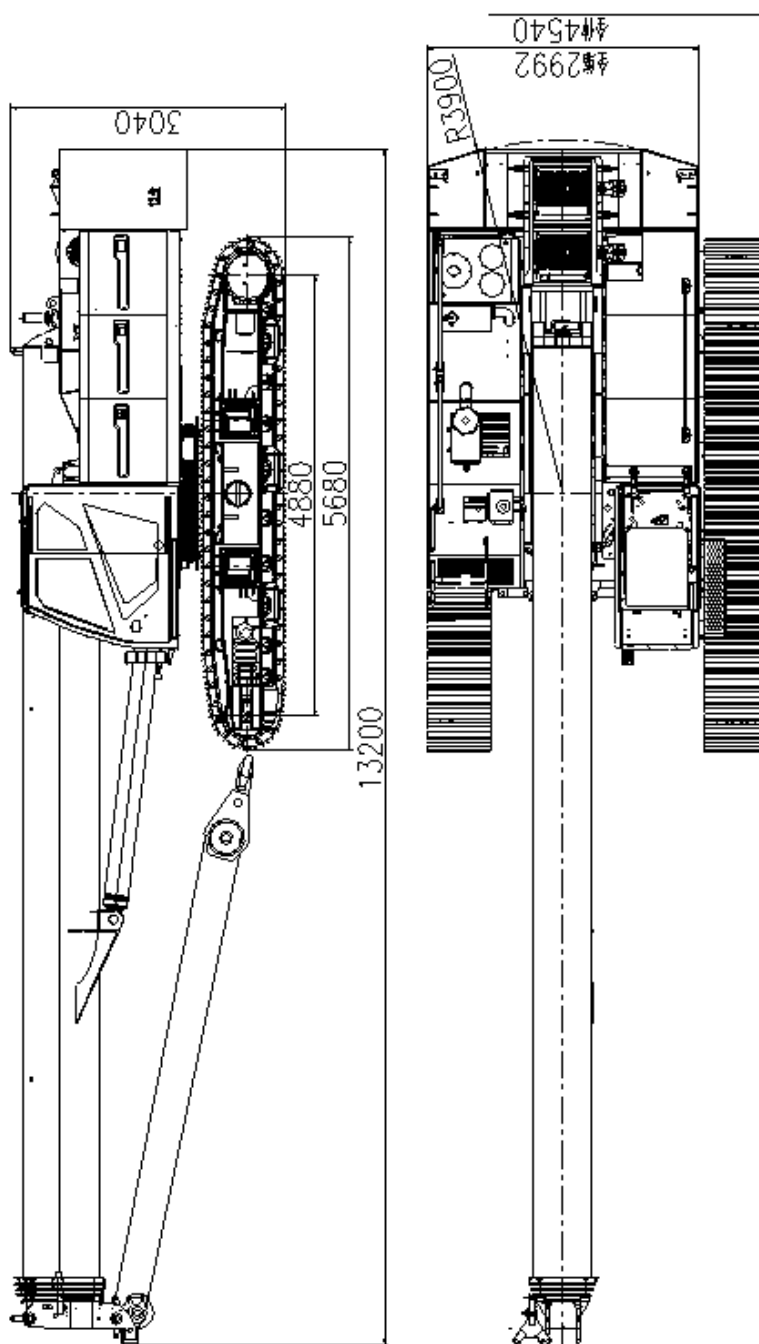

Figure 2-3 Overall dimensions

## 2.4.2 Main technical parameters

Main technical parameters of this crawler crane are shown in the table 2-4. The item in the table is not the standard configuration of crane. It is subject to the contract signed with the customer.

**Table 2-4 Main technical parameters**

Item	Unit	Value	Remarks
Max. lifting capacity	t	30	
Max. lifting moment	KN.m	1230	
Boom length	m	10.9-43	
Jib length	m	8	Optional
Max. length of boom with fixed jib	m	43+8	Optional
Boom angle	°	-1.5-80	
Jib angle	°	0, 15, 30	Optional
Max. single rope speed of the main hoisting winch	m/min	142	Unloaded, the 4th drum layer
Max. single rope speed of the auxiliary hoisting winch.	m/min	142	Unloaded, the 4th drum layer
Boom derricking up time	s	35	
Slewing speed	rpm	90	
Traveling speed	km/h	0-2.7	
Max. gradeability	%	0-2.5	
Ground pressure	MPa	45	
Deadweight	t	41.3	
Counterweight	t	12.5	
Overall dimensions (L x W x H)	mm	13200x4540(2990)x3040	
Engine	Model		Weichai WP6G190E301
	Rated power / rotational speed	kW/rpm	140/2000
	Max. output torque / rotational speed	Nm/rpm	860/1500
	Exhaust emission	/	Chinese National Stage 3

 **CAUTION**

The single rope speed of the winch, slewing speed and traveling speed vary with the load.

## 2.5 Lifting performance

### 2.5.1 Working radius

Unit: m

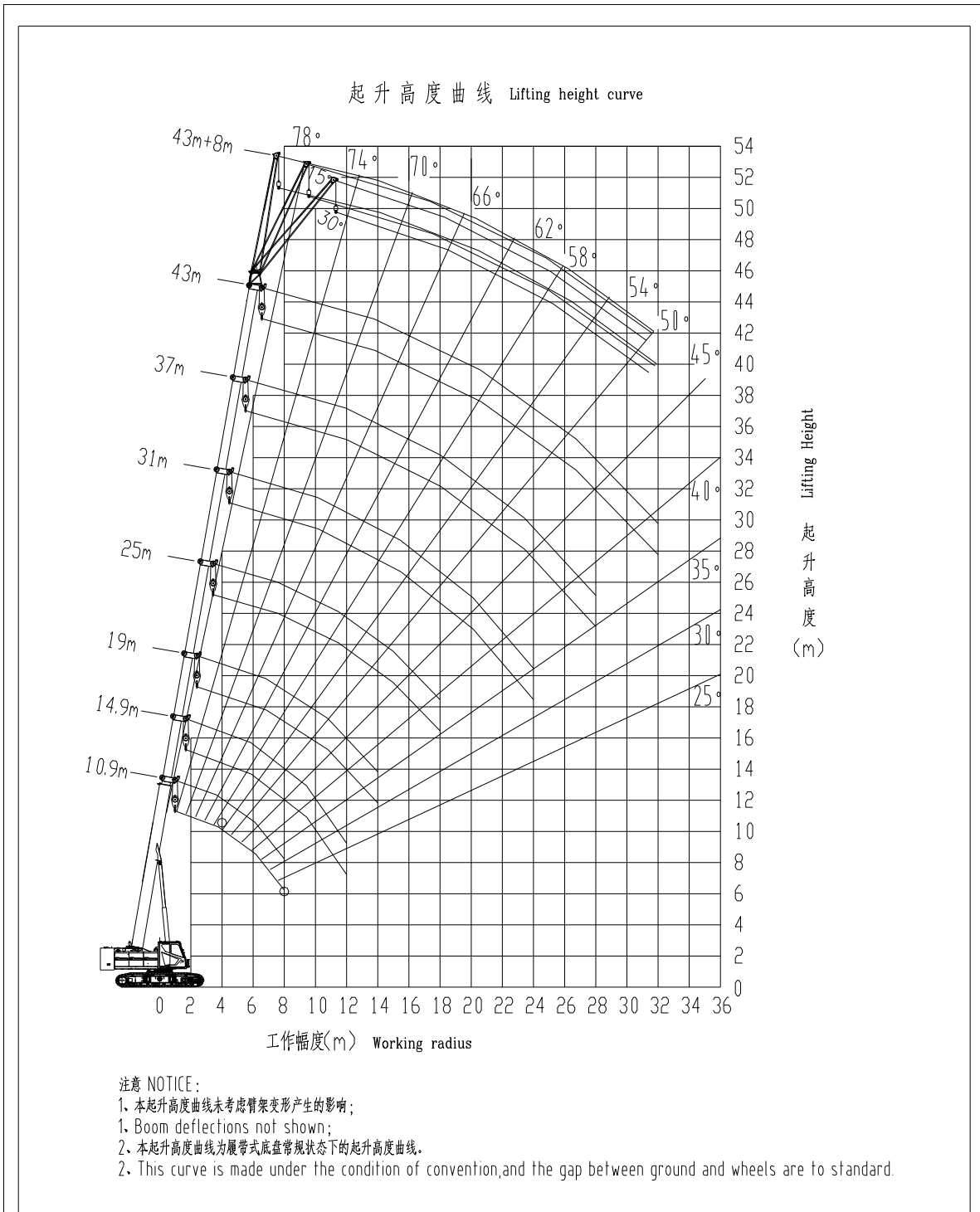

Figure 2-4 Lifting height chart

### 2.5.2 Rated capacity charts

There are different lifting capacities corresponding to various operating modes of this crane. The operator should determine a lifting capacity according to actual working conditions.

### 2.5.2.1 Rated lifting capacity for standing still

Table 2-3 Rated capacity chart

Unit: kg

Working radius (m)	Boom length (m)						
	TELESCOPIC CYLINDER I FULLY EXTENDED, crawler carriers fully extended, 360-degree full working range, 12.5 t counterweight, 0°						
	10.9	14.9	19	25	31	37	43
3.0	30000	29000					
3.5	30000	27500					
4.0	28500	26500	20500	19000			
4.5	26500	25500	20500	19000			
5.0	25100	24200	20500	19000			
5.5	22700	21200	20500	19000			
6.0	20500	19600	19000	18000	15000	10200	
7.0	15800	15100	14800	15600	14000	10200	
8.0	12500	12300	12100	13400	12600	10200	
9.0	10300	10000	9800	10500	11400	9900	7500
10.0		8300	8200	8900	9200	9100	7500
11.0		7000	6900	7600	8300	8300	7300
12.0		5900	5800	6400	6900	7600	6800
14.0			4200	4800	5100	5500	5900
16.0			3000	3700	4100	4500	4500
18.0				2800	3100	3400	3700
20.0				2100	2500	2800	3000
22.0				1500	1900	2100	2500
24.0					1500	1600	1900
26.0					1100	1200	1600
28.0					750	1050	1300
30.0						850	850
32.0							
34.0							
36.0							
I	0	4	8	8	8	8	8
II	0	0	0	6	12	18	24
Reeving	8	8	6	5	4	3	3
Hook	30t						

Table 2-4 Rated capacity chart

Unit: kg

Working radius (m)	Boom length (m)					
	TELESCOPIC CYLINDER I FULLY EXTENDED, crawler carriers fully extended, 360-degree full working range, 12.5 t counterweight, 2°					
	10.9	14.9	19	25	31	
3.0	21000	20300				
3.5	21000	19300				
4.0	20000	18600	11300	10500		
4.5	18600	17900	11300	10500		
5.0	17600	16900	11300	10500		
5.5	15900	14800	11300	10500		
6.0	14400	13700	10500	9900	6000	
7.0	11100	10600	8100	8600	5600	
8.0	8800	8600	6700	7400	5000	
9.0	7200	7000	5400	5800	4600	
10.0		5800	4500	4900	3700	
11.0		4900	3800	4200	3300	
12.0		4100	3200	3500	2800	
14.0			2300	2600	2000	
16.0			1700	2000	1600	
18.0				1500	1200	
20.0				1200	1000	
22.0				800	800	
24.0					600	
26.0						
28.0						
30.0						
32.0						
34.0						
36.0						
I	0	4	8	8	8	
II	0	0	0	6	12	
Reeving	8	8	6	5	4	
Hook	30t					

Table 2-5 Rated capacity chart

Unit: kg

Working radius (m)	Boom length (m)						
	TELESCOPIC CYLINDER I FULLY EXTENDED, crawler carriers fully extended, 360-degree full working range, 12.5 t counterweight, 4°						
	10.9	14.9	19	25	31		
3.0	18000	17400					
3.5	18000	16500					
4.0	17100	15900	9200	8600			
4.5	15900	15300	9200	8600			
5.0	15100	14500	9200	8600			
5.5	13600	12700	9200	8600			
6.0	12300	11800	8600	8100	4500		
7.0	9500	9100	6700	7000	4200		
8.0	7500	7400	5400	6000	3800		
9.0	6200	6000	4400	4700	3400		
10.0		5000	3700	4000	2800		
11.0		4200	3100	3400	2500		
12.0		3500	2600	2900	2100		
14.0			1900	2200	1500		
16.0			1400	1700	1200		
18.0				1300	900		
20.0				900	800		
22.0				700	600		
24.0							
26.0							
28.0							
30.0							
32.0							
34.0							
36.0							
I	0	4	8	8	8		
II	0	0	0	6	12		
Reeving	8	8	6	5	4		
Hook	30t						

Table 2-6 Rated capacity chart

Unit: kg

Working radius (m)	Boom length (m)						
	TELESCOPIC CYLINDER I INTERMEDIATELY EXTENDED, crawler carriers fully extended, 360-degree full working range, 12.5 t counterweight, 0°						
	10.9	14.9	20.9	26.9	32.9	38.9	
3.0	30000	29000					
3.5	30000	27500					
4.0	28500	26500	19000				
4.5	26500	25500	19000	15500			
5.0	25100	24200	19000	15500			
5.5	22700	21200	18300	15500			
6.0	20500	19600	18000	15500	11300		
7.0	15800	15100	15800	15200	11300		
8.0	12500	12300	13000	13400	10500	7800	
9.0	10300	10000	10600	11000	9700	7800	
10.0		8300	9200	9600	9000	7200	
11.0		7000	7800	8400	8200	6800	
12.0		5900	6800	7300	7300	6400	
14.0			5100	5700	5600	5400	
16.0			3900	4400	4500	4600	
18.0			3000	3400	3600	3700	
20.0				2700	2900	3000	
22.0				2100	2300	2500	
24.0				1700	1900	2000	
26.0					1500	1700	
28.0					1100	1300	
30.0					800	1000	
32.0							
34.0							
36.0							
I	0	4	4	4	4	4	
II	0	0	6	12	18	24	
Reeving	8	8	5	4	3	3	
Hook	30t						

Table 2-7 Rated capacity chart

Unit: kg

Working radius (m)	Boom length (m)						
	TELESCOPIC CYLINDER I INTERMEDIATELY EXTENDED, crawler carriers fully extended, 360-degree full working range, 12.5 t counterweight, 2°						
	10.9	14.9	20.9	26.9			
3.0	21000	20300					
3.5	21000	19300					
4.0	10000	18600	10500				
4.5	18600	17900	10500	6200			
5.0	17600	16900	10500	6200			
5.5	15900	14800	10100	6200			
6.0	14400	13700	9900	6200			
7.0	11100	10600	8700	6100			
8.0	8800	8600	7200	5400			
9.0	7200	7000	5800	4400			
10.0		5800	5100	3800			
11.0		4900	4300	3400			
12.0		4100	3700	2900			
14.0			2800	2300			
16.0			2100	1800			
18.0			1700	1400			
20.0				1100			
22.0				800			
24.0				700			
26.0							
28.0							
30.0							
32.0							
34.0							
36.0							
I	0	4	4	4			
II	0	0	6	12			
Reeving	8	8	5	4			
Hook	30t						

Table 2-8 Rated capacity chart

Unit: kg

Working radius (m)	Boom length (m)					
	TELESCOPIC CYLINDER I INTERMEDIATELY EXTENDED, crawler carriers fully extended, 360-degree full working range, 12.5 t counterweight, 4°					
	10.9	14.9	20.9	26.9		
3.0	18000	17400				
3.5	18000	16500				
4.0	17100	15900	8600			
4.5	15900	15300	8600	4700		
5.0	15100	14500	8600	4700		
5.5	13600	12700	8200	4700		
6.0	12300	11800	8100	4700		
7.0	9500	9100	7100	4600		
8.0	7500	7400	5900	4000		
9.0	6200	6000	4800	3300		
10.0		5000	4100	2900		
11.0		4200	3500	2500		
12.0		3500	3100	2200		
14.0			2300	1700		
16.0			1800	1300		
18.0			1400	1000		
20.0				800		
22.0						
24.0						
26.0						
28.0						
30.0						
32.0						
34.0						
36.0						
I	0	4	4	4		
II	0	0	6	12		
Reeving	8	8	5	4		
Hook	30t					

Table 2-9 Rated capacity chart

Unit: kg

Working radius (m)	Boom length (m)							
	TELESCOPIC CYLINDER I FULLY RETRACTED, crawler carriers fully extended, 360-degree full working range, 12.5 t counterweight, 0°							
	10.9	16.9	22.9	28.9	34.9			
3.0	30000	19000						
3.5	30000	19000						
4.0	28500	19000	18100					
4.5	26500	19000	18100					
5.0	25100	19000	18100					
5.5	22700	19000	18100	11300				
6.0	20500	18300	16500	10800	8600			
7.0	15800	16800	15500	10800	8400			
8.0	12500	13900	14000	10300	8100			
9.0	10300	11500	11700	9500	7800			
10.0		9700	9800	8800	7400			
11.0		8300	8300	8200	6900			
12.0		7200	7200	7200	6500			
14.0		5400	5800	6100	5300			
16.0			4600	4900	4700			
18.0			3600	4000	4100			
20.0			3000	3300	3300			
22.0				2700	2800			
24.0				2200	2300			
26.0				1800	1900			
28.0					1600			
30.0					1300			
32.0								
34.0								
36.0								
I	0	0	0	0	0			
II	0	6	12	18	24			
Reeving	8	6	5	4	3			
Hook	30t							

Table 2-10 Rated capacity chart

Unit: kg

Working radius (m)	Boom length (m)						
	TELESCOPIC CYLINDER I FULLY RETRACTED, crawler carriers fully extended, 360-degree full working range, 12.5 t counterweight, 2°						
	10.9	16.9	22.9	28.9			
3.0	21000	10500					
3.5	21000	10500					
4.0	20000	10500	10000				
4.5	18600	10500	10000				
5.0	17600	10500	10000				
5.5	15900	10500	10000	4500			
6.0	14400	10100	9100	4300			
7.0	11100	9200	8500	4300			
8.0	8800	7600	7700	4100			
9.0	7200	6300	6400	3800			
10.0		5300	5400	3500			
11.0		4600	4600	3300			
12.0		4000	4000	2900			
14.0		3000	3200	2400			
16.0			2500	2000			
18.0			2000	1600			
20.0			1700	1300			
22.0				1100			
24.0				900			
26.0				700			
28.0							
30.0							
32.0							
34.0							
36.0							
I	0	0	0	0			
II	0	6	12	18			
Reeving	8	6	5	4			
Hook	30t						

Table 2-11 Rated capacity chart

Unit: kg

Working radius (m)	Boom length (m)						
	TELESCOPIC CYLINDER I FULLY RETRACTED, crawler carriers fully extended, 360-degree full working range, 12.5 t counterweight, 4°						
	10.9	16.9	22.9	28.9			
3.0	18000	8600					
3.5	18000	8600					
4.0	17100	8600	8100				
4.5	15900	8600	8100				
5.0	15100	8600	8100				
5.5	13600	8600	8100	3400			
6.0	12300	8200	7400	3200			
7.0	9500	7600	7000	3200			
8.0	7500	6300	6300	3100			
9.0	6200	5200	5300	2900			
10.0		4400	4400	2600			
11.0		3700	3700	2500			
12.0		3200	3200	2200			
14.0		2400	2600	1800			
16.0			2100	1500			
18.0			1600	1200			
20.0			1400	1000			
22.0				800			
24.0				700			
26.0							
28.0							
30.0							
32.0							
34.0							
36.0							
I	0	0	0	0			
II	0	6	12	18			
Reeving	8	6	5	4			
Hook	30t						

### 2.5.2.2 Rated capacity chart for travelling with a suspended load

Table 2-12 Rated capacity chart

Unit: kg

Working radius (m)	Boom length (m)				
	TELESCOPIC CYLINDER I FULLY EXTENDED, 12.5 t counterweight, travel with a suspended load over the center front working area (lower than 0.4m/s), 0°				
	10.9	14.9	19	25	31
3.0	21000	20300			
3.5	21000	19300			
4.0	20000	18600	14400	13300	
4.5	18600	17900	14400	13300	
5.0	17600	16900	14400	13300	
5.5	15900	14800	14400	13300	
6.0	14400	13700	13300	12600	10500
7.0	11100	10600	10400	10900	9800
8.0	8800	8600	8500	9400	8800
9.0	7200	7000	6900	7400	8000
10.0		5800	5700	6200	6400
11.0		4900	4800	5300	5800
12.0		4100	4100	4500	4800
14.0			2900	3400	3600
16.0			2100	2600	2900
18.0				2000	2200
20.0				1500	1800
22.0				1100	1300
24.0					1100
26.0					800
28.0					
30.0					
32.0					
34.0					
36.0					
I	0	4	8	8	8
II	0	0	0	6	12
Reeving	8	8	6	5	4
Hook	30t				

Table 2-13 Rated capacity chart

Unit: kg

Working radius (m)	Boom length (m)				
	TELESCOPIC CYLINDER I FULLY EXTENDED, 12.5 t counterweight, travel with a suspended load over the center front working area (lower than 0.4m/s), 2°				
	10.9	14.9	19	25	
3.0	15000	14500			
3.5	15000	13800			
4.0	14300	13300	10300	9500	
4.5	13300	12800	10300	9500	
5.0	12600	12100	10300	9500	
5.5	11400	10600	10300	9500	
6.0	10300	9800	9500	9000	
7.0	7900	7600	7400	7800	
8.0	6300	6200	6100	6700	
9.0	5200	5000	4900	5300	
10.0		4200	4100	4500	
11.0		3500	3500	3800	
12.0		3000	2900	3200	
14.0			2100	2400	
16.0			1500	1900	
18.0				1400	
20.0				1100	
22.0				800	
24.0					
26.0					
28.0					
30.0					
32.0					
34.0					
36.0					
I	0	4	8	8	
II	0	0	0	6	
Reeving	8	8	6	5	
Hook	30t				

Table 2-14 Rated capacity chart

Unit: kg

Working radius (m)	Boom length (m)			
	TELESCOPIC CYLINDER I FULLY EXTENDED, 12.5 t counterweight, travel with a suspended load over the center front working area (lower than 0.4m/s), 4°			
	10.9	14.9		
3.0	15000	14500		
3.5	15000	13800		
4.0	14300	13300		
4.5	13300	12800		
5.0	12600	12100		
5.5	11400	10600		
6.0	10300	9800		
7.0	7900	7600		
8.0	6300	6200		
9.0	5200	5000		
10.0		4200		
11.0		3500		
12.0		3000		
14.0				
16.0				
18.0				
20.0				
22.0				
24.0				
26.0				
28.0				
30.0				
32.0				
34.0				
36.0				
I	0	4		
II	0	0		
Reeving	8	8		
Hook	30t			

Table 2-15 Rated capacity chart

Unit: kg

Working radius (m)	Boom length (m)				
	TELESCOPIC CYLINDER I INTERMEDIATELY EXTENDED, 12.5 t counterweight, travel with a suspended load over the center front working area (lower than 0.4m/s), 0°				
	10.9	14.9	20.9	26.9	
3.0	21000	20300			
3.5	21000	19300			
4.0	20000	18600	13300		
4.5	18600	17900	13300	10900	
5.0	17600	16900	13300	10900	
5.5	15900	14800	12800	10900	
6.0	14400	13700	12600	10900	
7.0	11100	10600	11100	10600	
8.0	8800	8600	9100	9400	
9.0	7200	7000	7400	7700	
10.0		5800	6400	6700	
11.0		4900	5500	5900	
12.0		4100	4800	5100	
14.0			3600	4000	
16.0			2700	3100	
18.0			2100	2400	
20.0				1900	
22.0				1500	
24.0				1200	
26.0					
28.0					
30.0					
32.0					
34.0					
36.0					
I	0	4	4	4	
II	0	0	0	0	
Reeving	8	8	5	4	
Hook	30t				

Table 2-16 Rated capacity chart

Unit: kg

Working radius (m)	Boom length (m)				
	TELESCOPIC CYLINDER I INTERMEDIATELY EXTENDED, 12.5 t counterweight, travel with a suspended load over the center front working area (lower than 0.4m/s), 2°				
	10.9	14.9	20.9	26.9	
3.0	15000	14500			
3.5	15000	13800			
4.0	14300	13300	9500		
4.5	13300	12800	9500	7800	
5.0	12600	12100	9500	7800	
5.5	11400	10600	9200	7800	
6.0	10300	9800	9000	7800	
7.0	7900	7600	7900	7600	
8.0	6300	6200	6500	6700	
9.0	5200	5000	5300	5500	
10.0		4200	4600	4800	
11.0		3500	3900	4200	
12.0		3000	3400	3700	
14.0			2600	2900	
16.0			2000	2200	
18.0			1500	1700	
20.0				1400	
22.0				1100	
24.0				900	
26.0					
28.0					
30.0					
32.0					
34.0					
36.0					
I	0	4	4	4	
II	0	0	0	0	
Reeving	8	8	5	4	
Hook	30t				

Table 2-17 Rated capacity chart

Unit: kg

Working radius (m)	Boom length (m)				
	TELESCOPIC CYLINDER I INTERMEDIATELY EXTENDED, 12.5 t counterweight, travel with a suspended load over the center front working area (lower than 0.4m/s), 4°				
	10.9	14.9			
3.0	15000	14500			
3.5	15000	13800			
4.0	14300	13300			
4.5	13300	12800			
5.0	12600	12100			
5.5	11400	10600			
6.0	10300	9800			
7.0	7900	7600			
8.0	6300	6200			
9.0	5200	5000			
10.0		4200			
11.0		3500			
12.0		3000			
14.0					
16.0					
18.0					
20.0					
22.0					
24.0					
26.0					
28.0					
30.0					
32.0					
34.0					
36.0					
I	0	4			
II	0	0			
Reeving	8	8			
Hook	30t				

Table 2-18 Rated capacity chart

Unit: kg

Working radius (m)	Boom length (m)				
	TELESCOPIC CYLINDER I FULLY RETRACTED, 12.5 t counterweight, travel with a suspended load over the center front working area (lower than 0.4m/s), 0°				
	10.9	16.9	22.9	28.9	
3.0	21000	13300			
3.5	21000	13300			
4.0	20000	13300	12700		
4.5	18600	13300	12700		
5.0	17600	13300	12700		
5.5	15900	13300	12700	7900	
6.0	14400	12800	11600	7600	
7.0	11100	11800	10900	7600	
8.0	8800	9700	9800	7200	
9.0	7200	8100	8200	6700	
10.0		6800	6900	6200	
11.0		5800	5800	5700	
12.0		5000	5000	5000	
14.0		3800	4100	4300	
16.0			3200	3400	
18.0			2500	2800	
20.0			2100	2300	
22.0				1900	
24.0				1500	
26.0				1300	
28.0					
30.0					
32.0					
34.0					
36.0					
I	0	0	0	0	
II	0	6	12	18	
Reeving	8	6	5	4	
Hook	30t				

Table 2-19 Rated capacity chart

Unit: kg

Working radius (m)	Boom length (m)				
	TELESCOPIC CYLINDER I FULLY RETRACTED, 12.5 t counterweight, travel with a suspended load over the center front working area (lower than 0.4m/s), 2°				
	10.9	16.9	22.9		
3.0	15000	9500			
3.5	15000	9500			
4.0	14300	9500	9100		
4.5	13300	9500	9100		
5.0	12600	9500	9100		
5.5	11400	9500	9100		
6.0	10300	9200	8300		
7.0	7900	8400	7800		
8.0	6300	7000	7000		
9.0	5200	5800	5900		
10.0		4900	4900		
11.0		4200	4200		
12.0		3600	3600		
14.0		2700	2900		
16.0			2300		
18.0			1800		
20.0			1500		
22.0					
24.0					
26.0					
28.0					
30.0					
32.0					
34.0					
36.0					
I	0	0	0		
II	0	6	12		
Reeving	8	6	5		
Hook	30t				

Table 2-20 Rated capacity chart

Unit: kg

Working radius (m)	Boom length (m)			
	TELESCOPIC CYLINDER I FULLY RETRACTED, 12.5 t counterweight, travel with a suspended load over the center front working area (lower than 0.4m/s), 4°			
	10.9	16.9		
3.0	15000	9500		
3.5	15000	9500		
4.0	14300	9500		
4.5	13300	9500		
5.0	12600	9500		
5.5	11400	9500		
6.0	10300	9200		
7.0	7900	8400		
8.0	6300	7000		
9.0	5200	5800		
10.0		4900		
11.0		4200		
12.0		3600		
14.0		2700		
16.0				
18.0				
20.0				
22.0				
24.0				
26.0				
28.0				
30.0				
32.0				
34.0				
36.0				
I	0	0		
II	0	6		
Reeving	8	6		
Hook	30t			

## 2.5.2.3 Rated capacity chart with the jib

Table 2-20 Rated capacity chart

Unit: kg

Boom angle ( ° )	Boom length (m)+ jib (m)		
	12.5t counterweight, crawler carriers fully extended, lift over 360° range (on flat ground)		
	43+8		
	0°	15°	30°
80	3000	2600	2000
78	2800	2600	1900
76	2800	2500	1800
74	2800	2300	1700
72	2600	2200	1600
70	2400	2100	1500
68	2200	1900	1350
66	1900	1700	1250
64	1600	1500	1100
62	1400	1300	1000
60	1200	1100	900
58	1000	900	750
56	800	700	600
54	700	500	500
52	600		
Reeving	1		
Hook	3t		

### CAUTION

- (1) All the above operating modes are only operational when the crawler carriers are extended, otherwise no lifting is permitted.
- (2) Inclination angles of complete vehicle in the above tables refer to the angle between either the traveling direction of the crane and the ground, or the direction vertical to the traveling direction and the ground.
- (3) The values given in the lifting capacity tables are the max. permissible lifting capacities under various OMs and specified operating conditions. The values as given in the tables include the mass of the hook (main hook: 285 kg, auxiliary hook: 80 kg) and slings.

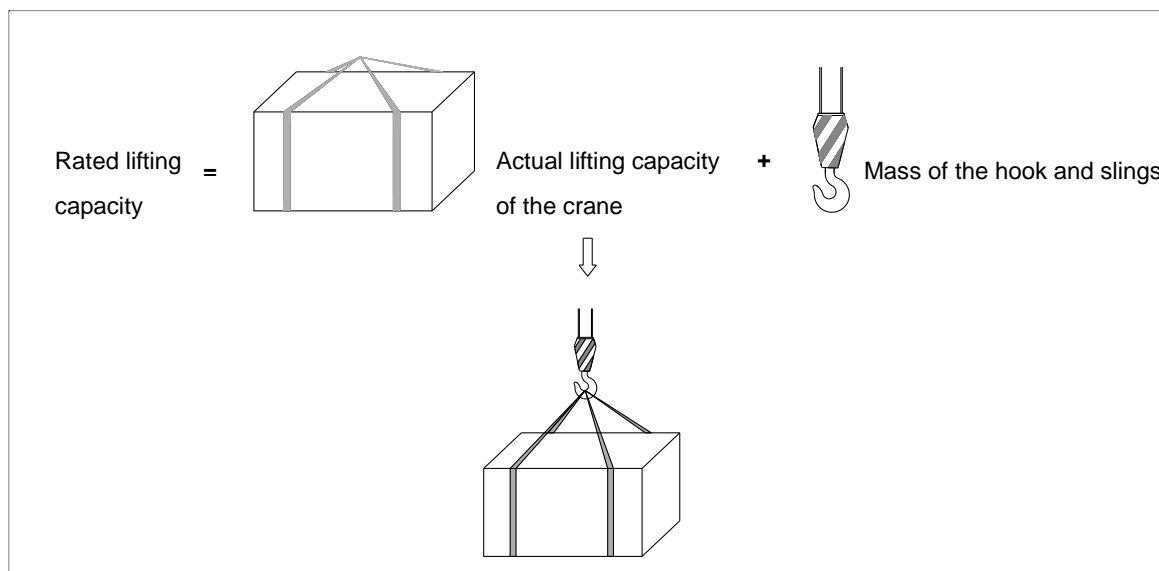

Figure 2-6 Total rated lifting capacity

- (4) A working radius is the horizontal distance between the gravity center of the hook block and the slewing center.
- (5) When the actual boom length and working radius are within two adjacent values in the above tables, the lifting capacity should be determined using method of interpolation. The lifting capacity displayed in the load moment limiter is only for reference.
- (6) If the jib or extension is mounted on the boom head during a lift operation, the rated lifting capacity should be further deducted by 320 kg.
- (7) The maximum lifting capacity for a lifting operation using the rooster sheave is 4000 kg. However, if the lifting capacity determined based on the lifting capacity table is smaller than this value, the smaller lifting capacity shall prevail.

For example:

For 31 m boom length and 10 m working radius, the lifting capacity after reference to the lifting capacity table is 3100 kg, which is smaller than 4000 kg, then the lifting capacity should be 3100 kg.

For 31 m boom length and 10 m working radius, the rated lifting capacity is 9200 kg after reference to the lifting capacity table, which is larger than 4000 kg. Then the lifting capacity should be 4000 kg.

- (8) It is prohibited to use both the main hook and the auxiliary hook to lift a load.
- (9) The lifting height charts do not take into consideration of changes of working radius and lifting height due to boom deflection.



- (1) When the boom length exceeds 30m, derricking of the boom should be conducted in strict accordance with the lifting height chart even if the boom is unloaded, otherwise the crane may tip over.
- (2) When the crane is working on a slope, the lifting capacity corresponding to the slope angle should be selected in the corresponding lifting capacity table. It is prohibited to operate the crane on a slope exceeding 4° .



# **ZOOMLION**

## **Operator's Manual for Telescopic Crawler Crane**

### **Chapter 3 Safety Guidelines**





## Chapter 3 Safety Guidelines

### 3.1 Operational planning

In addition to a perfect working crane and a well-trained crew, operational planning is an important precondition for safe and reliable crane operation.

The crane operator must obtain or receive the necessary information (familiarize himself with the operator's manual, basic knowledge about pneumatic, electrical and hydraulic drive, and notes for safe operation as well as operating environment) before starting the crane operation, in particular:

- a) Clearly define the duty and area of responsibility of all personnel concerned.
- b) Type of crane operation and the required working mode.
- c) Distance between the lifting points and surrounding buildings.
- d) Influence of communal facilities (including the overhead high/low voltage lines and underground gas pipes).
- e) Space requirements at the work site.
- f) Movement restrictions due to surrounding structures (e.g. is there another crane nearby in working).
- g) Number, weight, dimensions, material of load(s) to be lifted.
- h) Required lifting height and slewing radius.
- i) Load-bearing capacity and flatness of soil or ground to be operated upon.
- j) Height and width of thoroughfares leading to the site.
- k) Other factors affecting the working site (e.g. weather, live lines, etc.).
- l) Communication means adopted between signalman and crane operator.
- m) Take appropriate measures to keep people unconcerned and equipment away from the working area.

Basing on the above information, the crane operator must assemble the equipment required to operate the crane:

- Required boom configuration for crane operation
- Hook blocks/load hook
- Rope Reeving



- (1) A correct and complete operational planning is vital for safe and problem-free operation of the crane. The operation planner must plan a safe and reliable operational planning by obtaining and analyzing all necessary information about the operation and considering all the factors that may impair the safety of crane operation.**
- (2) If the crane operator does not possess all necessary and required information, it may prove impossible to carry out the intended work and accidents may occur!**

### 3.1.1 Lifting performance of the crane

The lifting height and rated lifting capacity in corresponding boom configurations can be found using the lifting capacity charts in Section 2.5 of Chapter 2.



**The crane can still pose a hazard or danger if safety procedures are not observed and implemented.**

### 3.1.2 Appropriate use

Appropriate use of the crane is a basic safety requirement that can never be compromised.

The crane must only be used for the operations stated and explained in this operator's manual and maintenance manual.

The safety precautions and protective measures relevant to the proper use of the crane during assembly and disassembly, commissioning, maintenance and repair are listed in this operator's manual.

Appropriate use of the crane can be considered when the following condition occurs:

- n) National safety requirements are adhered to properly.
- o) Accept and familiarize the safety information in this operator's manual.
- p) All safety devices are operational.
- q) Proper use of all kinds of fuel and lubricant as specified in this operator's manual.
- r) Appropriate use also includes proper maintenance and inspection of the crane. For details, refer to maintenance manual.



**Any other use of the crane without the manufacturer's written consent is always considered as inappropriate use. The crane owner or operator in this case is liable for any resultant damages.**

### 3.1.3 Examples of inappropriate use

Inappropriate use of crane is prohibited.

Examples of inappropriate use include the following items:

- a) Structural modifications to the crane without written consent of the manufacturer are prohibited.
- b) Commissioning the crane:
  - No acceptance test performed prior to operation.
  - Only authorized people can commission the crane.
  - Thorough understanding of the contents in the operator's manual.

- Operator's manual is incomplete and not in the local language.
- c) Hazardous operation of the crane.
- d) Transport of personnel on the superstructure or with the hoisting winches.
- e) Lifting a load on the ground with derricking winch.
- f) Dragging a load on the ground.
- g) Exercise diagonal pull exceeding 2% of the maximum permitted hoisting load.
- h) Crane operation without the prescribed safety devices such as load moment limiter and hoisting limiter.
- i) Crane operation without using proper lifting capacity charts.
- j) Installing spare parts not approved by the manufacturer.
- k) Tilting the crane.
- l) Improper lifting of persons in a mounting basket.
- m) Working in hazardous locations.



**Inappropriate use of the crane may result in:**

- (1) Life-threatening injuries and even death.**
- (2) Damage to the crane or major damage to property.**
- (3) Cancellation of the manufacturer's warranty.**

### 3.1.4 Areas of responsibility

#### 3.1.4.1 The manufacturer

- a) Responsible for the intact and complete condition of the supplied equipment, including any accessories and documentation.
- b) Monitor product performance, renew relevant document and conduct maintenance and service work.
- c) Provide global service and repair service.
- d) Open a training center and provide training for crane operator and maintenance personnel.

#### 3.1.4.2 The owner or an authorized person

- a) Ensure that only adequately trained and qualified personnel who have read and understood the operator's manual can operate and maintain the crane.
- b) Assign the duties and responsibilities to specific personnel involved in crane operation.
- c) Provide the necessary protective equipment for operator and maintenance personnel.
- d) Regularly remind all personnel at the job site of safety considerations during operation.
- e) Immediately shut down the equipment when hazard occurs.
- f) Perform inspections on the crane basing on national regulations.
- g) Perform inspections on the crane as required by the manufacturer.

- h) Verify that the crane has been serviced and maintained at the recommended intervals.
- i) Inform the manufacturer about every accident on the crane regarding serious injury or property damage.
- j) Allows the manufacturer's personnel unimpeded access to the crane in order to monitor the product performance.
- k) Make operational planning for the equipment.

#### **3.1.4.3 The crane operator:**

- a) Responsible for the safe operation of the crane.
- b) Must at all times wear the necessary protective gear for his personal safety.
- c) Verify that all of the controls in the cab are set to zero or neutral before starting up the engine.
- d) Check that the brakes and the emergency stop device are working properly prior to daily operation.
- e) Only operate the crane properly within the manufacturer's limitations as specified in the lifting capacity chart.
- f) Inform all irregularities that may affect safe operation of the crane to his supervisor or to the owner of the crane.
- g) Stop the operation at once if safe operation is no longer secured.
- h) Verify that all the controls are in the zero or neutral position and the engine is turned off prior to leaving the operator's cab.
- i) After operation, turn ignition starter switch to OFF position, unplug the keys in operator's cab and engine compartment, and lock the door in operator's cab to prevent unauthorized personnel from entering the cab.
- j) Keep the cab, the platforms and the steps clean and free from any debris.

#### **3.1.5 Work area**

While operating the crane:

- Only the crane operator is allowed to work on the crane.
- The crane operator cannot leave the cab, while the crane is operational in any manner.

The requirements are conducive to a safe and comfortable working environment:

- a) Always keep the cab clean, including the foot pedals, the ashtray, and only place drinks in the holders provided.
- b) Never place magazines or other objects on the control panels. Do not cover the control panel or load moment limiter.
- c) Never keep tools in the cab.
- d) Nothing is allowed to block the doors to the cab, such as clothing or parts of the protective gear or personal belongings etc.
- e) The cab must always be free from snow, ice and any other obstructions.
- f) The windows and the rear view mirror of the cab must be clean and free from condensation and ice.

## 3.2 Safety technical notes

### 3.2.1 Safety instructions

#### 3.2.1.1 Crane operator

The crane operator's primary responsibility is to control, operate and adjust the crane in a manner that is safe for both himself and others. Therefore the crane operator should meet the following requirements.

- a) The operator must be familiar with operator's manual, maintenance manual, and know the working principle, structure performance and the safety devices' function, as well as master the operation essentials and maintenance skills.
- b) The operator should inspect brake, load hook, wire rope and safety devices before operating the crane. Any irregularities detected during inspection should be removed immediately.
- c) The operator must focus his attention on his work during operation and is forbidden to chat with others. Generally speaking, the operator can only follow signal sent out by appointed persons. For a stop signal, the operator should obey it at all times, no matter who gives it. He should refuse to accept signal which violates operation regulations. Stop the crane immediately if somebody is found climbing the crane.
- d) Operator who is in low spirits or poor healthy is not allowed to operate the crane.
- e) Crane operator and slinger should be familiar with safety rules, signals and symbols. Prohibit operating the crane after drinking.
- f) Be qualified with the work in hearing, eyesight and reaction ability; be strong enough to operate safely, and has the ability to estimate distance, height and clearance correctly.
- g) Be familiar with the usage of fire extinguisher and be well trained; know how to survive under emergent conditions.
- h) Make sure that only authorized personnel or those who have the relevant certificates are allowed to operate the crane.

To make sure that the crane is kept in good working order, the crane operator should perform the following checks before operating the crane:

- a) Check if safety related items are placed in their specified positions;
- b) Check the crane maintenance record to confirm if regular maintenance and inspection have been carried out;
- c) Ensure that necessary repairs have been completed;
- d) Check the wire rope for damage (twist or rupture, etc.);
- e) Ensure that there is no unauthorized crane modification;
- f) Check the crane for air or oil leakage;

- g) Check if controls are in their specified positions before starting the engine;
- h) Check if all instruments and indicators can display normally before starting the engine;
- i) Test all control systems;
- j) Check brakes;
- k) Lift the load to a height 50 mm from the ground and then keep it still, so as to check the braking performance of the hoisting mechanism.

The operator should conduct checks on following safety devices to ensure their normal functioning:

- a) Hoisting limit switch;
- b) Boom angle indicator;
- c) External alarming lights and electric horn;
- d) Slewing locking device;
- e) Load moment limiter;
- f) Lowering limit switch.

To prevent occurrence of overloading, the operator should:

- a) Confirm weight of the load to be lifted;
- b) First set a small working radius when beginning a lift operation, and then increase the working radius gradually during the process;
- c) Confirm the weight of the hook and wire rope;
- d) Confirm the main boom length, jib length and lifting area coverage;
- e) When the target boom length or working radius is located between two adjacent values in the lifting capacity table, use the larger boom length or working radius value to determine the rated lifting capacity;
- f) Only lift a load after confirming that it is within the rated lifting capacity;
- g) Only install the counterweight system of suitable weight;
- h) Do not conduct a lift operation if the wind force poses a potential danger. Derrick down the main boom to a lower height when necessary;
- i) Refer to the *Rated Lifting Capacity Manual* for other possible limitations;
- j) Prevent the boom from suffering from any lateral load;
- k) Avoid colliding the main boom with the load or other objects;
- l) Release the load slowly to prevent the boom from suffering from shock during the process;
- m) Locate the main boom right above the load before the lifting operation.
- n) Ensure that the load can be lifted freely.
- o) If the boom is derricked down with a suspended load, the working radius will increase, which would cause overloading and crane tipping over. The operator shall operate in strict accordance with the load rating manual.

During lifting operations, the operator shall not conduct following improper operations:

- a) Excessively high speed slewing or abrupt start/stop.
- b) Fast braking with a suspended load;
- c) Drag or tow the load when the boom is not aligned with the load center.
- d) Wraps of wire rope are not laid neatly on the drum;
- e) Overloading or improper tying of a heavy load;
- f) Travelling too fast with a suspended load, or lift a load on an uneven ground;
- g) Abrupt release of a heavy load;
- h) Rotation of a heavy load in the air;
- i) Collision of the load with boom, bridge, ceiling, or high pressure power line;
- j) Improper disassembling of the boom;
- k) Start of slewing operation before the left and right crawler tracks are fully extended to their maximum position;
- l) Start of a lifting operation before the left and right crawler tracks are fully extended to their maximum position;
- m) Boom telescoping with a suspended load;
- n) Immediate operation after the boom is fully retracted (wait 2 s before further operations!)
- o) Continuing to operate the crane when the levelness exceeds its normal range ( $X < 1\%$ ,  $Y < 1\%$ ); Adjust levelness of the crane before further operations!

### 3.2.1.2 Rigger

The rigger is responsible for ensuring that the load is attached or released safely and carefully. Therefore, he only uses suitable, undamaged lifting and slinging equipment to prevent the load from either slipping or falling. If no signalman is available, the rigger works directly with the crane operator.

Qualifications for rigger:

- a) Be qualified with the work in hearing, eyesight and reaction ability;
- b) Be strong enough to move hook or component;
- c) Be able to estimate the load, balance the load and judge the distance, height and clearance correctly;
- d) Be trained in the skill of handling load;
- e) Be able to choose proper load handling device and components according to the loading condition;
- f) Be trained in hand signals for operation and familiar to use them;
- g) Be able to safely use audio equipment (such as interphone) to send out oral order exactly and clearly;
- h) Be capable of conducting and controlling the crane to move the load safely;
- i) Make sure that only authorized personnel are allowed to carry out the work.

### 3.2.1.3 Signalman

The main job of signalman is to assist crane operator to carry out safe operation. Potential damage to property or personal injury could be avoided if the crane operator carries out the crane movement following the signals given by appointed signalman. However, only one signalman or rigger may work with the crane operator at a time.

Qualifications for signalman:

- a) Familiar with the lifting task so as to cooperate with crane operator and other workers;
- b) Make sure that only authorized personnel are allowed to carry out the work;
- c) Be qualified with the work in hearing, eyesight and reaction;
- d) Be able to estimate the distance, height and clearance correctly;
- e) Be trained in hand signals for operating and familiar to use them;
- f) Use standard hand signals for crane operation. If necessary, use a radio device to send out correct and clear order;
- g) Be capable of conducting and controlling the crane to move the load safely;
- h) Position himself in a safe location from where he can see the whole process of operation and be seen clearly by the personnel.



**In your interests and in the interests of others, please learn to command your crane according to instructions and familiarize yourself with all the dangers associated with the work to be carried out.**

### 3.2.2. Points for attention for crane operating crew

- a) Any unsafe operation must be corrected or any dangerous situations must be reported to supervisor.
- b) All the persons in the vicinity of the crane must observe the acoustic warning signals of the crane so as to ensure himself and others safety.
- c) All the workers must know about the task to be carried out and proceeding sequence;
- d) Check whether dangerous situations occur during operation of the crane, and inform crane operator and signalman of the unsafe factors such as high-voltage power line, unauthorized persons, obstacles and poor ground conditions.

### 3.2.3 Points for attention during crane operation

Observe the rated lifting capacity of crane and working radius specified in load capacity charts. All unintended operations that might pose hazards are prohibited.



- (1) **The crane is not allowed to work at working radius which is not specified in load capacity charts. This case is also applicable to the condition that the load is not attached to the load hook. If not, there is a risk of accident.**
- (2) **Check that the number of wire rope reeving specified in load capacity charts matches with the maximum lifting capacity of crane. If not, the wire rope may be broken and accidents may occur.**
- (3) **Slowly activating and stopping all crane movements can prevent load from swinging. If the wire rope on the winding drum is unwound to the last layer, an operator must check the drum to see if there are three windings of wire rope left on the drum. If less than three windings of wire rope remains on the drum, serious accident may occur.**
- (4) **Do use appropriate load hook whose lifting capacity matches the actual load to be lifted.**

### 3.3 Requirements for operating site

#### 3.3.1 Selecting an operating site

It is very important to choose an appropriate location for crane operation in order to minimize safety risks. The operating site should be selected so that:

- Crane movement can be carried out within the smallest possible radius.
- No obstacles hinder necessary movements.
- The ground is able to support expected loads.



**The most essential requirement for safe crane operation is working on firm ground with the capacity to support your loads.**

#### 3.3.2 Slopes and trenches

The crane may not be set up too close to slopes or trenches. A safety distance must always be kept from them depending on the type of soil.

Safety distance is measured from the foot of the trench and it is:

- Soft or backfilled soil = 2x depth of trench ( $A_2 = 2 \times T$ )
- Hard or grown soil = 1x depth of trench ( $A_1 = 1 \times T$ )

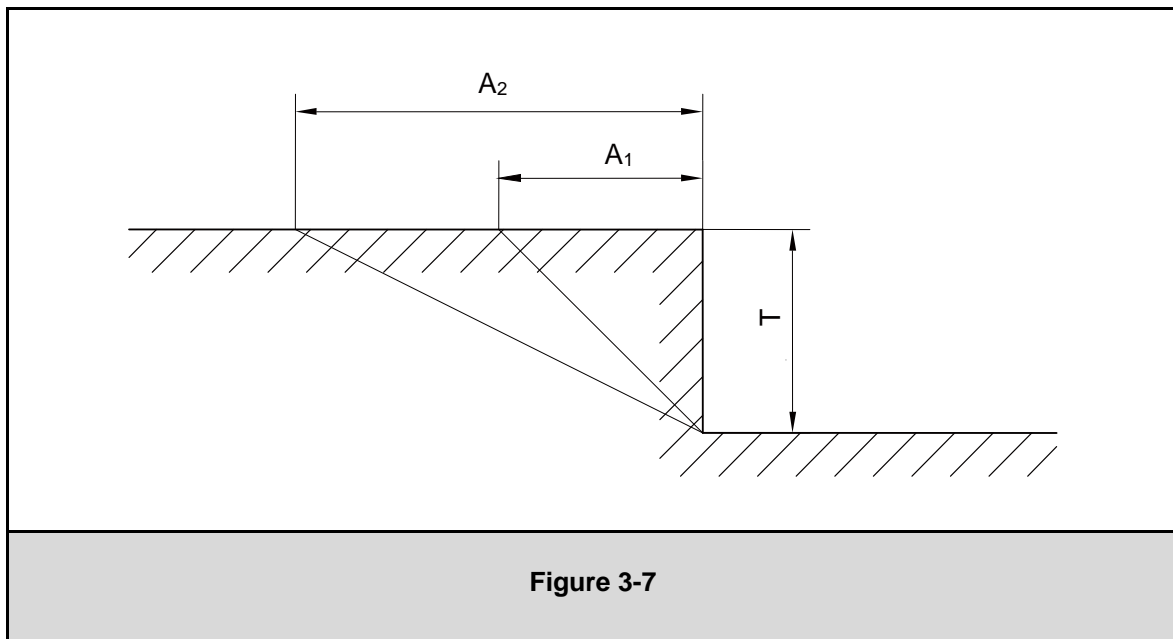



If a safe distance is not maintained, the slope or trench must be firmly filled. Otherwise, there is a danger that the edge of the slope or trench will collapse and the crane may topple.

### 3.3.3 Permissible ground pressure

Before crane operation, the load bearing capacity of the ground must be verified under different boom configurations. Ensure the  $1.25 \cdot P_{\max} < [\delta]$  ( $P_{\max}$  refers to the maximum ground pressure of crane and  $[\delta]$  the bearing capacity of the ground).

The ground must not collapse during crane operation. Take corresponding measures in accordance with different ground pressure to satisfy various bearing capacities.

Permissible bearing capacity is shown in the table 3-1.

**Table 3-1 Bearing capacity of various ground**

Soil type		Load bearing capacity $[\delta]$ , MPa		
A) Back-filled, not naturally compacted ground		0-0.1		
B) Natural soil, apparently undisturbed	1. Mud, peat, marshy soil	0		
	2. Non-cohesive, sufficiently compactly layered soil	Fine to medium grained sand;	0.15	
		From coarse-grained sand to gravel	0.2	
	3. Cohesive soil:	Loamy;	0	
		Soft;	0.04	
		Stiff;	0.1	
		Semi-solid;	0.2	
	4. Rock with few fissures	Hard	0.4	
		In healthy, un-weathered condition and in a favorable location:		1.0
			In cohesive layer order	1.5
	In massive or column-style shape	3.0		
C) Artificially compacted ground	1. Asphalt	0.5-1.5		
	2. Concrete	Concrete group B I	5-25	
		Concrete group B II	35-55	

 **CAUTION**

- (1) If there is any doubt about the load-bearing capacity of the ground at the operating site, ground test should be carried out.
- (2) The load-bearing capacity of the ground at the operating site should be 125% of the rated load of the crane.

 **DANGER**

It is forbidden to lift a load when the ground bearing capacity is uncertain. Otherwise accidents may occur.

### 3.3.4 Checking safety measures

The ground should be firm and flat. The gradient should not be greater than 1%.

The safety condition of the ground should be checked thoroughly prior to operating the crane, including:

- a) Check whether the ground provides adequate load-bearing capacity.
- b) Check whether there is sufficient safety clearance to slopes and trenches.
- c) Check whether the crane is adjusted to be horizontal.
- d) Check whether there are live electrical wires within the working range of the crane.
- e) Check whether there are obstacles which will hinder required crane operation.

 **CAUTION**

The crane operation belongs to dangerous operation. So much attention should be given to the working condition of the crane before and during crane operation.

### 3.4 Working weather

- a) At the job site, the ambient temperature should vary between  $-20^{\circ}\text{C}$  and  $40^{\circ}\text{C}$ .
- b) When the wind velocity exceeds  $13.8\text{m/s}$  during crane operation, stop operation immediately and retract the main boom to its driving position.

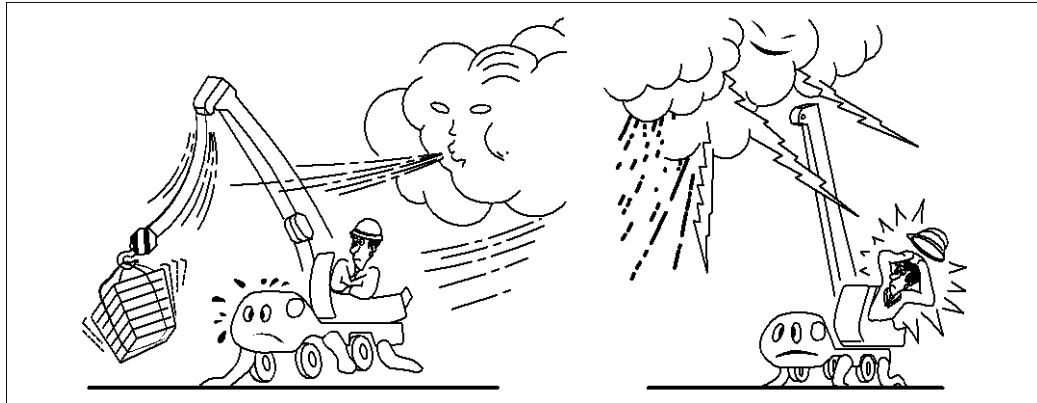

Figure 3-2 Wind, thunder and lightning

### 3.5 Electromagnetic influences

Strong electromagnetic fields are likely to be present if the construction site is close to a transmitter.

In any case, before working with the crane near transmitters, contact Zoomlion representative. In addition, consult a high frequency specialist.

- a) Every crane must be “totally” grounded. Check visually or with a simple tester to ensure that the ladder, cab and cable pulleys are grounded.
- b) All personnel working on the crane or with large metal objects must protect themselves from burns by wearing non-conductive gloves and clothing while working.
- c) If one feels a little increase in temperature, there is no need to panic. This is because the respective workpiece, structural steel member or undercarriage becomes “hot”.
- d) The temperature of objects affected by high frequency radiation depends on their “size”. For example, cranes, undercarriage and coverings are “hotter”.
- e) Contact with other crane loads is not permitted when moving the crane. Since defects caused by burns may considerably reduce rope carrying capacity, any such occurrences must be reported immediately to the machinery supervisor so that the ropes can be inspected.
- f) An insulator is required at all times between the crane load hook and tackle. It is strictly prohibited to remove this insulator.
- g) The ropes are strictly prohibited from touching the above insulator.

- h) Crane with attached loads may not be touched by any unprotected parts of the body after the load has been lifted or put down.
- i) Do not work with a bare upper torso or in short pants, this is prohibited.
- j) To minimize absorption of high frequency radiation, loads should be transported horizontally if possible.
- k) Loads must be grounded, or additional insulation used (rubber material between the tools used and gloves) when manual work is required.
- l) To avoid accidents, use a safety belt when working on components that are high off the ground.
- m) Handling explosive matter (such as refueling) may only be carried out at least 6 m away from the place where sparks could form due to handling of large metal parts. Use only rubber hoses to refuel.
- n) Any accidents and unexpected events must be reported immediately to the local project manager or the safety engineer.



**These electromagnetic fields can pose direct or indirect danger to persons or objects, for example:**

- (1) Effect on human organs due to temperature increase.**
- (2) Danger of burns or inflammation due to temperature increase.**
- (3) Spark or electric arc formation.**

## 3.6 Underground cables

With special equipment, the crane can also be used for underground working.

**In underground working, it is possible to damage:**

- a) Underground electric cables.
- b) Gas pipes.
- c) Telephone, TV, and data cables.
- d) Sewage pipes, district heating supply pipes, etc.

**To avoid damaging the underground equipment, take protective measures during operational planning:**

- a) The construction company is responsible for gathering accurate information about possible underground cables within the working area of the crane so that work can be done safely;
- b) Obtain relevant information from the relevant utility companies.
- c) Examine the "as completed" plans of:
  - 1) Utility companies (electricity, gas or water companies)
  - 2) Cable users (telephone companies, factories, transport companies)
  - 3) Building authorities.
- d) Only use the latest, up-to-date plans.
- e) If there are any deviations or extensions to a project, initiate new inquiries.
- f) If in doubt, localize the underground cables around the site using a locating device.
- g) The relevant utility companies, cable users and public authorities:
  - must be informed in good time about the start of the work;
  - Must be asked for written approval for the civil engineering work to be done.
- h) When several construction companies are involved, their activities must be coordinated. All companies must have the same up-to-date information on underground pipes, etc. on the construction site.

**Safety precautions and protective measures when operating the equipment near underground cables**

- a) Do not start work unless you have obtained all the approvals from the utility companies and the cable users.
- b) The equipment operator must obtain all relevant information about the exact location of all underground cables before starting work. These plans must be readily accessible at the construction site.
- c) Operate the equipment with particular care near underground cables, all applicable national safety guidelines as well as the special guidelines and safety measures of the utility companies must be noted and obeyed.

- d) In the event of any unexpected encounters with underground cables or associated warning tapes and protective coverings, cease working with the equipment immediately and inform the appropriate superiors.
- e) It is prohibited to uncover underground cables with the equipment. The underground cables must only be uncovered manually with blunt tools by the appropriate personnel who is responsible for the cables.
- f) Secure, support, or prop up all exposed underground cables so that they cannot sway, slide, or become deformed.
- g) Stabilize the cable ducts and trenches and secure the edges to prevent caving.

#### **Notes in connection with gas pipes**

- a) Whenever the position of the gas pipe casing changes or the casing is damaged, report this to the appropriate gas company. The gas pipe can only be backfilled after inspection, repair, and approval by specialist personnel from the gas company.
- b) All devices of the gas supply network around the site must remain accessible (fittings, valve boxes, manhole covers, etc.).
- c) Existing markings and information signs must not be covered, rearranged or removed.

#### **The consequences of a gas pipe's damage**

The escaping gas:

- a) Forms an inflammable gas-air mixture around the affected area.
- b) Can strike personnel or equipment if it is under high pressure.
- c) Not only endangers personnel and equipment on the site, but also passers-by and residents in the neighborhood.

#### **What must the crane operator do if a gas pipe is damaged and gas escapes, or a leak is suspected?**

- a) Stop work immediately.
- b) Leave the crane after shutting down the engine and all additional fuel powered units.
- c) Alert all site personnel, avoid producing any sparks and maintain a strict no-smoking policy.
- d) Switch off all construction equipment and shut down the engine near the construction equipment.
- e) Clear the danger area and secure a wide area with barriers. Do not allow access by unauthorized personnel.
- f) Inform the relevant gas company of the following information:
  - 1) The extent of the damage.
  - 2) The exact location of the site.
  - 3) The exact circumstances of the accident.
  - 4) How long ago the accident occurred.
  - 5) A name and telephone number for a return call.

- g) If there is the slightest suspicion that the gas is leaking into a building, alert the local occupants by knocking or calling. Do not ring the door bell or call them by telephone, as this may trigger an explosion.
- If the odor of gas is present in the building, especially around the area where the gas pipe enters the house; do not operate any electrical systems or equipment. Open all doors and windows widely for ventilation purposes and leave the building immediately.
- h) In the event of major damage, evacuate the occupants of all the surrounding buildings with the cooperation of the police or fire department.
- i) Building site personnel:
- Must assist all specialist personnel from the gas company during the repair work.
  - Can only leave the building site with the consent of the specialist personnel.
- j) Work on the building site can only begin again if authorization has been given by the relevant gas company.



**Extinguishing a gas fire requires specialist knowledge.**

**A gas fire that has already been extinguished can flare up again if more gas escape and break out in an unexpected spot.**

**Precautions:**

- (1) Alert the local fire department to fight the fire.**
- (2) Do not attempt to put out the fire before the fire department arrives unless lives are in danger or there is risk of major damage to property.**
- (3) If the gas fire is not causing any immediate danger, it is sometimes better, in certain circumstances, to let the gas burn. As soon as the gas company shuts off the gas pipe, the fire will extinguish itself.**

## 3.7 Checking safety measures

Before beginning any work, the crane operator must be convinced that the crane is in safe operating condition. All safety devices, such as load moment limiter, hoist limiter switches, brakes, limit switches, and boom angle indicator etc., are in good working order.

- a) The load moment limiter must be set according to the current crane configuration.
- b) The lifting height of crane as given in the load capacity charts must be adhered to. The load given in the load capacity charts must not be exceeded.
- c) The crane operator must know the weight and dimensions of the load before operating the crane.
- d) Load handling devices, lifting equipment and hook block must be in accordance with specified requirements.
- e) Make sure that the weight of hoisting and lifting equipment is subtracted from the load given in the load capacity charts.

## 3.8 Crane operation with a load

### 3.8.1 Operating conditions

- a) All components of the crane are in running-in state at the initial operating period. So, for the first 100 operating hours, the working load should not be too great and the working speed should not be too high. The maximum lifting load cannot exceed 80% of its rated load. And the maximum working speed is forbidden.
- b) The crane can work only when there is no fault, and the operator should maintain and check the crane regularly.
- c) The ground on jobsite should be firm and flat and the gradient should not be greater than 1%. The complete vehicle should be level and the supporting ground should not collapse during operating. If the ground is soft, a steel plate should be placed under the track pad. Otherwise, the ground may collapse and the crane may turn over.
- d) The permitted temperature range for crane operation is  $-20^{\circ}\text{C}$  –  $40^{\circ}\text{C}$ . Relative humidity should not exceed 85%. However, high humidity up to 100% is only permitted for a short period of time. The crane should be operated and supported on a ground lower than 1000m above sea level. If there are special requirements for ambient temperature and altitude of job site, please consult the engineer of Zoomlion.
- e) The maximum in-service wind velocity should not be more than 9.8m/s during operation. Stop crane operation immediately and retrace the main boom to its driving position if this limit is exceeded; otherwise there is a risk of danger and accident, as shown in the figure below.

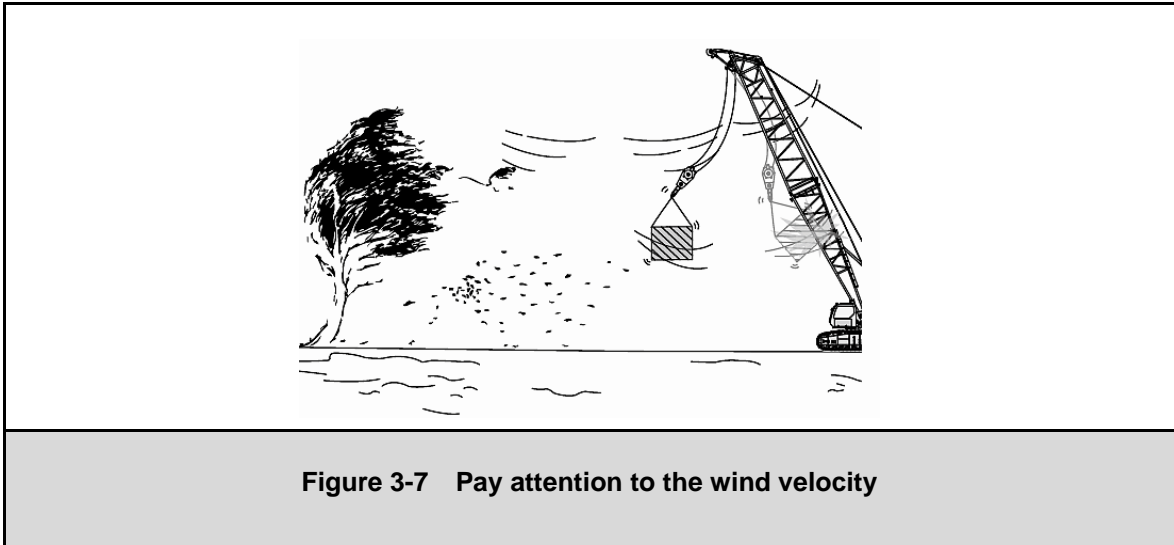

With the following table, the wind force and wind velocity can be estimated correctly:

**Table 3-2 Wind force beaufort**

Wind force		Effects of the wind in the inland	
Beaufort	Description	Wind speed (m/s)	Visual effects
0	Calm	0-0.2	No wind, smoke rises straight up
1	Light air	0.4-1.4	Wind direction is shown only by observing the trail of smoke, not by the wind sock
2	Light breeze	1.6-3	Wind can be felt on the face, the leaves rustle, wind sock moves slightly
3	Gentle breeze	3.4-5.3	Leaves and thin twigs move. Wind extends a small breeze flag.
4	Moderate breeze	5.5-7.8	Swirls up dust and loose paper, moves twigs and thin branches
5	Fresh breeze	8-10.6	Small deciduous trees begin to sway, foam forms at sea.
6	Strong breeze	10.8-13.7	Thicker branches move; telephone lines begin to whistle, umbrellas are difficult to use
7	Stiff wind	13.9-17	Entire trees swaying; difficult to walk into wind
8	Gale force wind	17.2-20.6	Breaks twigs of trees, walking becomes difficult
9	Gale	20.8-24.5	Minor damage to property(chimney tops and roofing tile are blown off)
10	Severe gale	24.7-28.3	Trees are uprooted, significant damage to property

### CAUTION

Before operation, crane operator must receive information on the expected wind velocity from the responsible meteorological authorities.

If impermissible wind velocity is forecasted, lifting a load is prohibited or even lowering the boom completely is needed.

- f) When the crane is working near the high-voltage power line, the safe clearance between any part of the crane and overhead power line should comply with the following regulations, otherwise accident may occur.

The safe clearance from high-voltage power lines should comply with the requirements in table 3-3:

**Table 3-3 Safe clearance from high-voltage lines**

Output voltage of high-voltage power line (V, kV)	$V \leq 1$	$1 < V \leq 15$	$15 < V \leq 40$	$40 < V \leq 100$	$100 < V \leq 200$
Safe clearance (m)	1.5	3	4	5	6

### CAUTION

If, despite all precautions having been taken, a flashover occurs, carry out the following procedures:

- (1) Keep calm!
- (2) Do not leave the crane cab.
- (3) Warn those people around the crane not to move or touch the crane.
- (4) Move the crane away from the danger area.

### DANGER

Not observing the above points can lead to (fatal) accidents and damage!

### 3.8.2 Instructions for safety operation

- a) No person is allowed to stand under the boom when the crane is operated. Otherwise, accident may occur.
- b) No person is allowed to stand on the slewing table during a lifting operation.
- c) It is forbidden to lift the load when someone stands on it. Refer to figure 3-10.
- d) Overloading operation and lifting staggered load is prohibited. Never pull load obliquely. Refer to figure 3-11.
- e) It is forbidden to lift the load hidden in the ground, frozen on the ground or connected to

other things. Otherwise, the crane may topple over, and the boom may be broken. Refer to figure 3-12.

- f) The crane can travel with the rated load. In this case, the ground should be firm and its gradient should not be more than 1%. The traveling speed must be less than 0.4 m/s. The boom must be located in the traveling direction. The distance between the load and the ground should not be more than 50cm. The longer the boom, the slower the travelling speed. Meanwhile lower the distance between the load and the ground as possible as you can.
- g) If the crane is operated in the vicinity of transmission systems (e.g. transmitters), strong electromagnetic field will be generated there, so measures should be taken to protect the crane against high frequency interference and all workers who stand on large metal plate should wear special isolating gloves and clothes to avoid being burnt.
- h) Under any condition, there must be at least three windings of wire rope left on the hoisting drum.
- i) When a load is suspended in the air, the operator is not allowed to leave the cab. The condition shown in figure 3-14 is prohibited.
- j) Operation should be carried out stably and gently. Never operate control lever jerkily and carry out switchover operation abruptly.
- k) When actual load reaches 90% of the rated one, the load moment limiter will sound an alarm, to which high attention should be given.
- l) Getting on and off the crane should be careful to avoid casualty. Persons may only access and leave the crane following permission from the crane operator and only when the crane is at a complete standstill! Hold the handrail when climbing up and down the crane.
- m) It is prohibited to make any modifications to the crane without permission; otherwise you should take the consequences. Unqualified person is forbidden to repair the crane and change the parts.
- n) Stop the crane operation if one of the following conditions occurs:
  - 1) The crane is overloaded or the weight of load is uncertain;
  - 2) The load falls down due to bad binding or hanging;
  - 3) No protective mat is added between the edges of load and wire rope;
  - 4) In case of poor visibility and /or darkness, it is difficult to identify load or signal;
  - 5) There is defect or damage of structural members or components which will impair safe operation, for example, the brake and safety equipment fail, or the wire rope is damaged etc.
- o) Leave an ample space for stopping crane; otherwise persons nearby may be hurt by crane counterweight due to narrow distance between counterweight and surrounding building.
- p) Keep the windows of crane operator's cab clean to ensure good visibility; stop crane operation immediately in case of poor visibility; replace the broken window as soon as possible.

- q) Keep the crane clean and dry, since slippery walkway, ladder, tools or loose parts may cause operator to fall down from crane.
- r) Travel the crane with great cautiousness, in working site or not. Observe the conditions surrounding the crane such as overhead power line, low-lying land, narrow clearance, restriction to bridge and road, uneven ground and gradient of road. If necessary, appoint a signalman to assist the operator to move the crane. Lock slewing mechanism during traveling.
- s) It is more dangerous that two cranes carry out lifting operations together. Therefore, a careful calculation must be made before commencing the work, and the following import requirements for this type of operation must be observed.
  - 1) The load is not casually attached to the crane. It must be calculated carefully so that the actual lifting capacity of the crane can not exceed the rated lifting capacity.
  - 2) Ensure that each lifting tackle can bear specified load weight which is calculated during design.
  - 3) The crane operator, signalman and other workers must evaluate the operational planning together before operation.
  - 4) Ensure that the crane can move properly in the whole process of operation.
- t) When you leave the crane in an emergency, take the following measures prior to leaving the crane.
  - 1) Detach the load from the hook and set it down on the ground; if necessary, lower the boom;
  - 2) Apply slewing brake or lock slewing mechanism;
  - 3) Brake or lock travel gear;
  - 4) Cut off power supply or switch off engine;
  - 5) Lock the control lever in off-state position.
- u) Do not wear loose clothing, scarves, open jackets or open shirt sleeves, and do not wear jewellery (rings, bracelets, earrings or similar). Otherwise, there is serious danger of injury from being pulled into moving machine parts.
- v) Do not stop crane near the bank which is possible to collapse or on low-lying land that may be washed away by water.
- w) Take away the key when the crane remains idle. In this way, unauthorized person can not start the crane without permission.
- x) Unqualified person is forbidden to repair the crane and change the parts.

### 3.8.3 Preparation and checks for crane operation

#### 3.8.3.1 Preparation for crane operation

Crane operator should perform the following checks before operating the crane:

- a) Check the daily record of work to ensure that all regular inspections, maintenance and repair work has been performed.
- b) Check the hoisting limit switch, boom angle indicator, and other safety equipment for functional work.
- c) Check if the load-bearing parts such as wire rope (hoisting rope, derricking rope etc.), boom, folding brackets, hook and load handling devices are kept in good working order.
- d) Check if there are some bolts, nuts and pins lost, and the components are cracked or damaged.
- e) Ensure that no modification has been made to the crane without permission, e.g., weight increase or decrease in counterweight plate and improper repair of the boom.
- f) After starting up the engine, check if the values shown on instruments are normal.
- g) Check fuel lines and hydraulic oil lines for leakage.
- h) Check all control mechanisms for functional work.
- i) Check brakes and clutch. Test the braking performance by lifting a load away from the ground and suspend it in the air for a moment.
- j) Keep the communication between the operator and rigger smooth.
- k) Estimate the weight and dimensions of load to be lifted in advance. Make sure no overloading or dragging happens.
- l) Crane operation can be carried out within minimum working radius. No obstacles hinder necessary movements. The ground at the operating site is able to support expected loads.
- m) Ensure that no obstacles are within the working radius and the operator can see the load clearly from the cab. Check if the communication between the operator and signalman is kept smooth so as to ensure safe crane operation.
- n) Determine the load-bearing capacity of the ground to be operated upon. Ensure that the crane is supported properly and never operate the crane on soft and uneven surface or on the ground of high water content or covered with frozen soil.  

If the ground does not have adequate load-bearing capacity, the crane is liable to tip over. In this case, crosstie, steel plates should be padded underneath the crawler to distribute load so that the load-bearing capacity of the ground will not be exceeded.

Make sure that the crane is leveled and the ground gradient should not be greater than 1%. Ensure that the groove or trench is reinforced when the crane is working near the groove or trench.
- o) Make sure that the crane is operated on level ground and the inclination is not more than 1% ( $\pm 0.57^\circ$ ).

### 3.8.3.2 Checks and points for attention during operation

- a) Estimate the weight and dimensions of load to be lifted in advance. Make sure no overloading or dragging happens.
- b) Use load handling devices (wire rope or chain) correctly. Make the vertical line of hook pass through center of gravity of load.
- c) If any part of the crawler crane or load handling devices comes into contact with high-voltage line, or other emergent situation occurs, the operator should stop the vehicle at once.
- d) The load capacities as given in the load capacity charts must be adhered to. The loads given in the load capacity charts must not be exceeded. Driving (or slewing) too fast with a load, or loading on an uneven surface, and swinging of suspended load should be avoided.
- e) Diagonal pulling, slewing or travelling of the load to be lifted which is still in contact with the ground is prohibited.
- f) It should be avoided that the load or auxiliary lifting device collides with structural members of crawler crane.
- g) If the crane gets caught in a thunderstorm during operation, the following measures should be taken at once:
  - Stop work on the crane immediately.
  - Retract the main boom as much as possible.
  - Apply brake or lock the winch and slewing gear.
  - Shut down the engine and cut off the power of load moment limiter and limit switch.
  - Ask all crane workers to leave.
- h) If the crane is struck by thunderbolt, the following checks should be performed:
  - Check whether there are burnt or damaged components.
  - Check the performance of electrical parts and load moment limiter.
  - Check the associated components for functional work.
- i) If earthquake occurs when the crane is operated, the following measures should be taken immediately:
  - Stop work on the crane immediately.
  - Release the load onto the ground;
  - Retract the main boom to its driving position as much as possible.
  - Brake or lock the winch and slewing gear.
  - Shut down the crane engine and cut off the power of the load moment limiter and limit switch.
  - Ask all crane workers to leave.

After earthquake, the following checks should be performed prior to crane operation:

  - Check the performance of electrical parts and load moment limiter.
  - Check the associated components for functional work.
- j) When working in the vicinity of power cables, a sufficient safety clearance must be maintained, if the cables are not isolated by electricity engineers or the hazardous area is

- not fenced off.
- k) If any part of the crawler crane or load handling device is in contact with high-voltage lines, the best way to guarantee the personal safety of the operator is to stay in the operator's cab until the danger is obviated. If the operator must leave the crane, he'd better jump rather than climb down the cab.
  - l) The operator's cab should be equipped with an emergency hammer which can be used to smash the window in an emergency so that the operator can escape from the cab.
  - m) The load moment limiter, once be triggered, should be kept in that state until the crane is not overloaded.
  - n) If the load moment limiter is not set according to the actual configuration status of the crane, it cannot fulfill its function as a safety device.
  - o) Check if the angle indicators and the tension force sensor are functioning.
  - p) The crane may topple over backwards if the load suddenly falls down, since the tension created in the boom can cause it to jerk back violently.
  - q) For all crane movements, the crane operator must always observe the condition of load, as well as the load hook or loading equipment when the crane is not loaded, in his field of vision. If this is not possible, the crane operator may only operate the crane according to instructions given to him by a signalman. These instructions may be given in the form of hand signals or over a two-way radio. Whatever method is used, precautions must be taken to eliminate the risk of misunderstanding.

### 3.8.3.3 Checks and points for attention after operation

- a) When the crawler crane and auxiliary lifting device are in non-working condition, never park the vehicle near the embankment liable to collapse or low-lying land subject to be washed away by water.
- b) Lower the load onto the ground and derrick down the main boom if necessary; brake or lock the slewing mechanism; apply the parking brake and traveling mechanism brake.
- c) Shut down the engine and cut off power. Lock the control lever in off-state position.
- d) Check if there is leakage in someplace and repair it if necessary.
- e) Clean such components as movable parts and exposed part of the piston rod of cylinder.
- f) Check if bolts and nuts are fitted tightly. Any defects found should be eliminated at once. It is prohibited to operate the crane with fault.
- g) Record the operating conditions and abnormal symptoms.
- h) Check if the quantity of tools and accessories meet specified requirements.
- i) Lock the operator's cab and safety devices.
- j) Take precaution measures against storm or lightning strikes.
- k) Take precaution measures against frostbite in winter.



- (1) When the temperature drops in winter, check whether the cooling water is correctly**

added with antifreeze.

- (2) To avoid engine from freezing in winter, drain all cooling water when park the vehicle.





### 3.9 Safety signs

There are safety signs affixed on the crane and important components before the crane delivery.

#### 3.9.1 Safety signs on the operator's cab

The safety signs on the operator's cab are shown as follows:

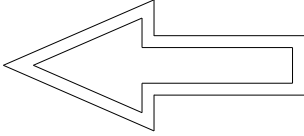
**Table 3-4 Safety signs on the operator's cab**

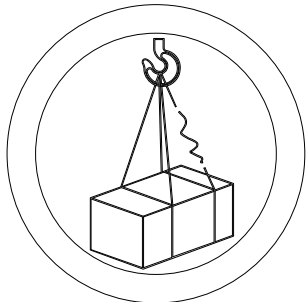
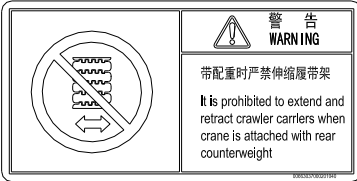
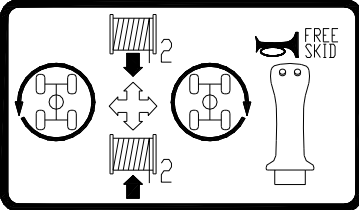
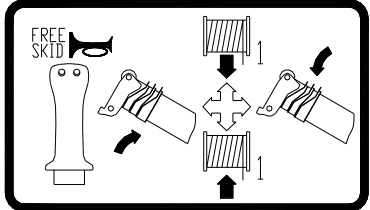
		
Unauthorized personnel prohibited	Fire extinguisher	No entry
		
Operating direction	Caution, risk of falling	Caution, risk of falling load
		
Do not extend/retract crawler carrier when the counterweight is assembled	Right joystick illustration	Left joystick illustration





		
Exit	Do not telescope with suspended loads	Cautions
		
Operation of slewing fixing pin spindle	Read the manual before operation	
		
Crane nameplate	Information on environment protection	
		
Sign of pedals		



Table 3-7 Safety signs on the operator's cab

<p>Note: Operation of slewing fixing pin spindle</p>	<p>Note: Read the manual before operation</p>
<p>Note: Free-fall operation</p>	<p>Note: Operation of crawler carriers</p>
<p>Note: Product name plate</p>	<p>Note: Information on environment protection</p>
<p>Note: signs of pedals</p>	

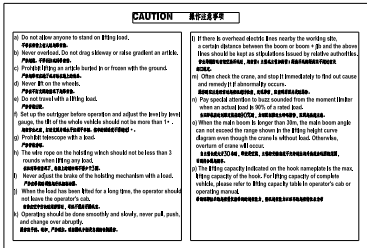
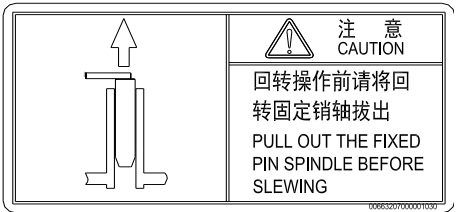
### 3.9.2 Safety signs on the slewing table

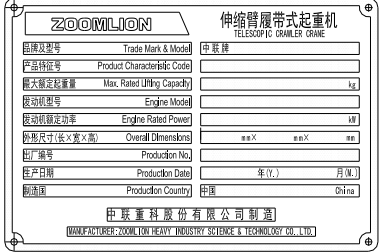
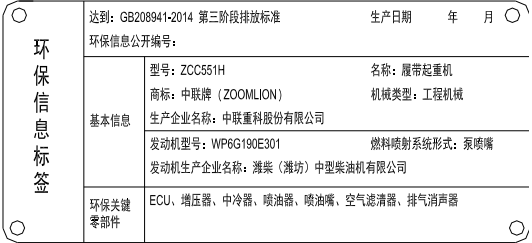
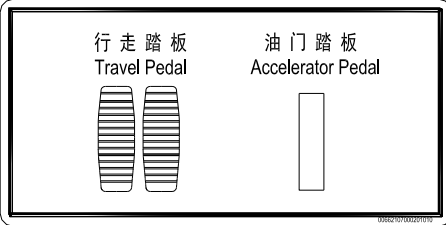
The safety signs on the **slewing table** are shown as follows:

**Table 3-5 Safety signs on the slewing table**

	
Hydraulic oil tank	Diesel tank
	
Be careful in the working radius	Never climb the machine during operation

### 3.9.3 Safety signs on the undercarriage

The safety signs on the **undercarriage** are shown as follows:

**Table 3-6 Safety sign on the undercarriage**

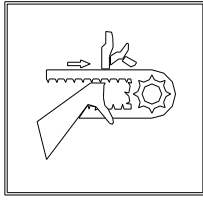
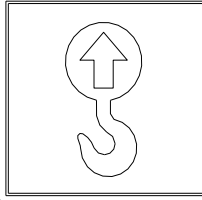
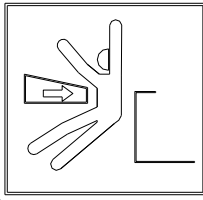
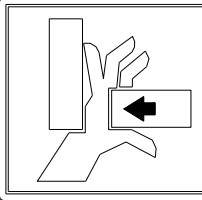
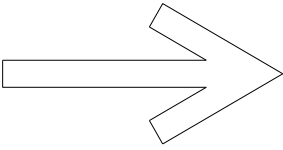
 <p>警告 WARNING</p> <p>运动部件绞手，切勿靠近 Keep away from moving parts</p>	 <p>提示信息 INFORMATION</p> <p>起吊位置，请根据实际情况选择吊具 Lifting point. Choose proper load handling device</p>
<p>Warning: Dragging / entanglement</p>	<p>Lift point</p>
 <p>危险 DANGER</p> <p>当心支腿外伸，工作区域 严禁站人 Keep off folding brackets/additional supports</p>	 <p>注意 CAUTION</p> <p>活动部件，小心夹手 Keep away from moving parts</p>
<p>Warning: Crushing / collisions</p>	<p>Warning: Keep away from moving parts</p>
	
<p>Traveling direction</p>	

### 3.9.4 Safety signs on the boom system

The safety signs on the **boom system** are shown as follows:

**Table 3-7 Safety signs on the boom system**







- (1) When the safety sign is damaged or illegible, please order it from appointed service supplier.
- (2) It is forbidden to cover or take off safety signs as you wish.
- (3) If the safety sign is covered with dust, clean it in time.
- (4) The operator's cab should be equipped with an emergency hammer which can be used to smash the window in an emergency so that the operator can run away from the cab.
- (5) The signs described above may differ in the real crane. The actual signs should be referred to.

### 3.10 Hand signals for controlling crane operations

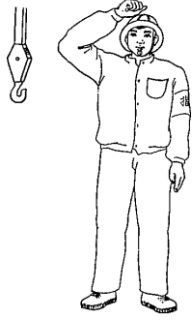
The recommended hand signals refer to the following table:

**Table 3-8 Hand signals for controlling crane operations**

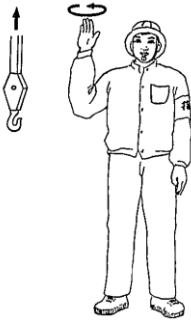
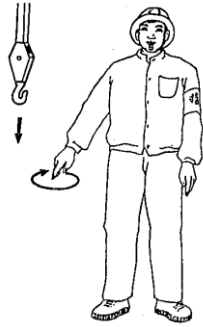

Ser. No.	1	2	3
Signal	Preparation	Use main hoist	Use auxiliary hoist
Description	Arm stretched out over the head, palm of the hand facing forwards.	Tap fist on the safety helmet; then use regular signals.	Bend one hand and hold it upward, tap the elbow with the other hand; then use regular signals.
Illustration			

Ser. No.	4	5	6
Signal	Hoist	Lower	Raise load slowly
Description	With forearm vertical, palm of the hand facing forwards, move hand in small horizontal circle.	With arm extended downwards with a 30° angle to the body, palm of the hand facing inwards, move hand in small horizontal circle.	With forearm vertical, palm of the hand facing upwards, wave hand up repeatedly.
Illustration			

**Table 3-8 Hand signals for controlling crane operations (continued)**

Ser. No.	7		8
<b>Signal</b>	Rotate		Lower load slowly
<b>Description</b>	Turn left: With right forearm vertical, the palm of the hand facing outwards, lower the forearm sideways horizontally, fingers pointing in the direction of rotation.	Turn right: With left forearm vertical, the palm of the hand facing outwards, lower the forearm sideways horizontally, fingers pointing in the direction of rotation.	With arm extended downwards with a 30° angle to the body, palm of the hand facing downwards, wave hand down repeatedly.
<b>Illustration</b>			
Ser. No.	9		10
<b>Signal</b>	Rotate slowly		Indicate load lowering position
<b>Description</b>	Turn left: With right forearm vertical, the palm of the hand facing outwards, move forearm horizontally and repeatedly, fingers pointing in the direction of rotation.	Turn right: With left forearm vertical, the palm of the hand facing outwards, move forearm horizontally and repeatedly, fingers pointing in the direction of rotation.	Extend the fingers to point at the position the load should fall on.
<b>Illustration</b>			

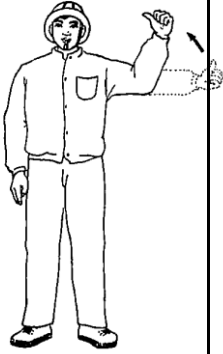
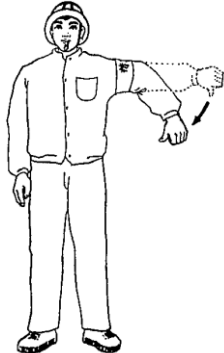
Table 3-8 Hand signals for controlling crane operations (*continued*)

Ser. No.	11	12	13
<b>Signal</b>	Raise boom	Lower boom	Raise boom slowly
<b>Description</b>	With arm stretched sideways horizontally, thumb pointing upwards, the remaining fingers closed, wave forearm up.	With arm stretched sideways horizontally, thumb pointing downwards, the remaining fingers closed, wave forearm down.	Bend one hand with thumb pointing upwards; place other hand motionless above hand moving up and down.
<b>Illustration</b>			

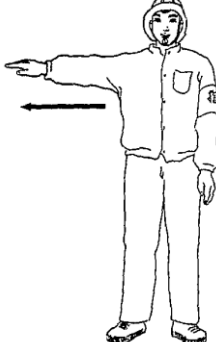
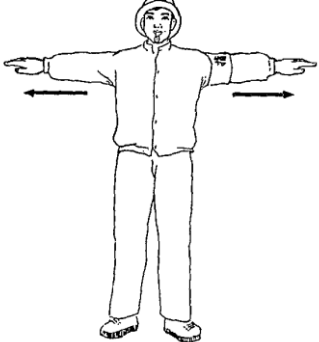
Ser. No.	14	15	16
<b>Signal</b>	Lower boom slowly	Stop	Emergency stop
<b>Description</b>	Bend one hand with thumb pointing downwards; place other hand motionless below hand moving up and down.	Arm extended, the palm facing downwards, move the arm back and forth horizontally.	Both arms extended, palms facing downwards, move arms back and forth horizontally.
<b>Illustration</b>			

**Table 3-8 Hand signals for controlling crane operations (continued)**

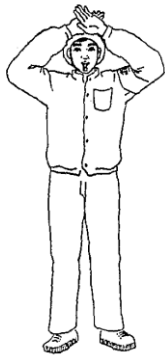
<b>Ser. No.</b>	17		
<b>Signal</b>	End of a movement		
<b>Description</b>	With fingers extended, cross both hands before the forehead.		
<b>Illustration</b>			

**! CAUTION**

- (1) We recommend using the hand signals illustrated above. However, users can decide on their own hand signals depending on actual condition, as different countries and regions may differ in the expression of hand signals.
- (2) Hand signals must first be discussed and mutually agreed upon and clearly executed. Misunderstanding of hand signals may lead to serious accidents.
- (3) In any case, international or local operational regulations must always be observed when abroad.

# **ZOOMLION**

## **Operator's Manual for Telescopic Crawler Crane**

### **Chapter 4 Crane Operation**





## Chapter 4 Crane Operation

### 4.1 Operating and control instruments

#### 4.1.1 Operator's cab overview



**Figure 4-1 Arrangement of components in operator's cab**

**Table 4-1 Components in operator's cab**

No.		Description
1	Tri-color light	Displays current load ratio status. Green: normal; yellow: warning; red: alarm.
2	Upper control panel	Electrical switches are arranged on the panel
3	Air conditioner control panel	Switches for controlling the air conditioner are arranged on the panel
4	Seat adjustment lever	For adjusting the position of the driver's seat
5	Safety lever	This lever should be applied before the driver enters or exits the cab so as to avoid misoperation; it should be disengaged before operation, otherwise all joystick controls are invalid (and the deadman switch on the joystick is not pressed).
6	Left control panel	Pre-selection of derricking/telescoping movement; Pre-selection of cylinder I/II; Cab tilting switch (optional); Bypass switch; Horizontal cylinder selection switch
7	Left joystick	Horn button and free swing button
8	Left and right travel pedals (with control levers)	For controlling travelling of the left and right crawlers
9	Emergency stop button	For shutting down the engine in an emergency
10	Monitoring system display	For monitoring the winches and right side of the crane
11	Load moment limiter display	Displays the load ratio, working status, and alarm information.
12	Right joystick	Free swing button and slewing lock button
13	Accelerator pedal	Controls engine speed.
14	Right control panel	Power for load moment limiter; ignition starter switch, main and auxiliary winch switch; hand throttle
15	GPS (inside the maintenance box)	Vehicle positioning
16	Cigarette lighter /USB	Press and then pull it up to light a cigarette; for USB power supply
17	Interior light switch	Press it to turn on the interior illumination light
18	Fan switch	For turning on the fan
19	Roof wiper switch	For turning on the roof wiper

### 4.1.2 Upper control panel

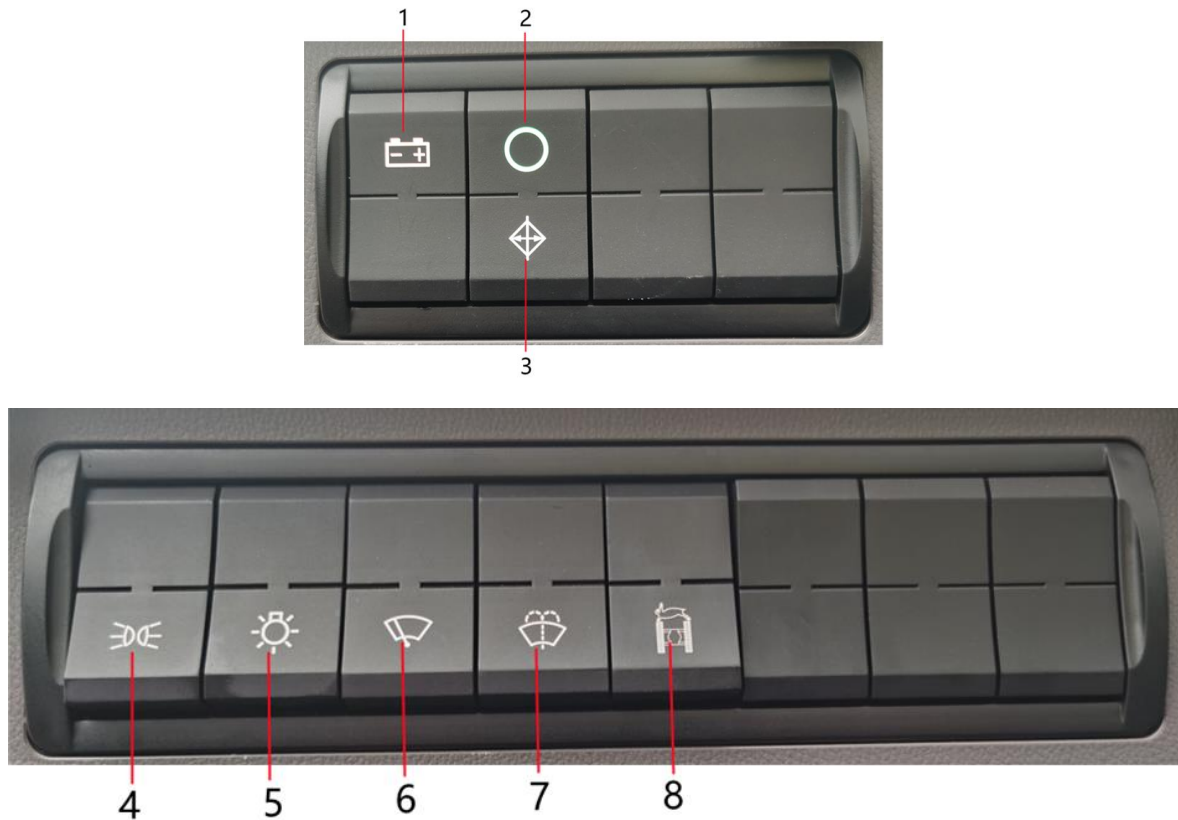

Figure 4-2 Arrangement of switches on upper control panel

Table 4-2 Description of switches on upper control panel

No.	Switch	Description
1	Control light Charging malfunction	Illuminates when the generator has a malfunction.
2	Control light Power	When the ignition switch is turned to ON position, this light illuminates.
3	Control light Hydraulic oil cooler (Reserved)	Reserved
4	Working light switch	When this light is turned on to position I, backlight of all rocker switches turns on; when it is turned to position II, working light of the slewing platform and boom turns on beside the above mentioned backlights.
5	Corner marking light switch	Press this switch to turn on the corner marking lights at boom head and tail of slewing platform.

6	Front windshield wiper switch	Press this light to turn on the front windshield wiper
7	Front windshield cleaner switch	Press this switch to turn on the cleaner and enable the sprayer to spray detergent onto the front windshield to clean the glass.
8	High speed travel switch	Press this switch to enable high speed traveling of the crane.

### 4.1.3 Right control panel



**Figure 4-3 Right control panel**

**Table 4-3 Functions of the right joystick**

No.	Part	Description
1	Power switch, load moment limiter	Press this switch to turn on the load moment limiter
2	Ignition starter switch	Turn this switch to position II to turn on the power and then turn further clockwise to start up the engine. When it is released, it will return to position II automatically.
3	Main winch switch	Turn on this switch and operate the right joystick to control the main winch.
4	Auxiliary winch switch	Turn on this switch and operate the left joystick to control the auxiliary winch.

5	Hand throttle	Rotate this switch to control engine speed
---	---------------	--------------------------------------------

### CAUTION

- Reset the ignition starter switch each time before starting up the engine.
- In cold weather, it is normal to have a delayed engine start as the engine preheating is in progress.

#### 4.1.4 Left and right joysticks



Figure 4-4 Left and right joysticks

Table 4-4 Functional description of the left and right joysticks

No.	Part	Description
1	Deadman switch (left joystick)	Press this switch to enable superstructure movements
2	Horn button	Press this switch to turn on the horn

3	Free swing button (left joystick)	Press this switch to enable free swing movement of the slewing platform
4	Left joystick	<ul style="list-style-type: none"> <li>- Controls the auxiliary winch: push it forward to reel off the wire rope; pull it backward to spool up the wire rope;</li> <li>- Control slewing movements: push it leftward to slew to the left; push it rightward to slew to the right</li> </ul>
5	Deadman switch (right joystick)	Press this switch to enable superstructure movements
6	Free swing button (right joystick)	Press this switch to enable free swing movement of the slewing platform
7	Slewing lock button	Press this switch to lock and unlock slewing movement.
8	Right joystick	<ul style="list-style-type: none"> <li>- Control derricking movements: push it leftward to derrick up the boom (telescope in the boom); push it rightward to derrick down the boom (telescope out the boom).</li> <li>- Controls the man winch: push it forward to reel off the wire rope; pull it backward to spool up the wire rope.</li> </ul>

### 4.1.5 Left control panel

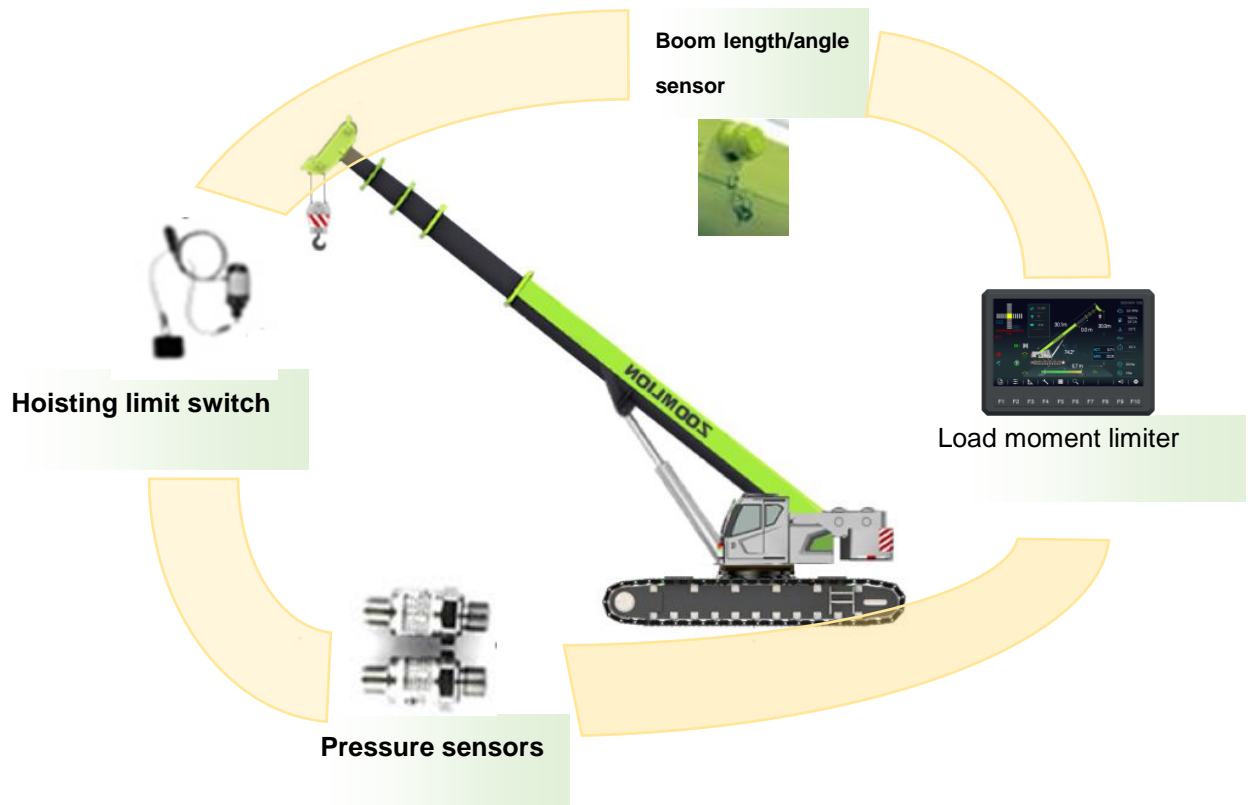

Figure 4-5 Left control panel

**Table 4-5 Functional description of the left control panel**

No.	Part	Description
1	Pre-selections switch Derricking/telescoping	Turn this switch to the left position before derricking the boom; Turn this switch to the right position before telescoping the boom.
2	Pre-selection switch Telescopic cylinder I/II	Before telescoping the boom, turn this switch to the left position to select the telescopic cylinder I for further operations; turn it to the right position to select the telescopic cylinder II for further operations;
3	Pre-selection switch Crawler horizontal cylinder extension/retraction	Turn this switch to the left position to extend the horizontal cylinder; turn it to the right position to retract the horizontal cylinder; turn to the center position to stop the movement.
4	Bypass switch	Rotate this switch clockwise to remove limitation on dangerous superstructure movement into a dangerous direction in case of overloading, overwinding, overlowering or no safety device is installed . This switch is only intended to be used during crane commissioning and maintenance.
5	Cab tilting switch (optional)	Turn this switch to tilt the cab up or down (reserved).

### 4.2 Computer system



**Figure 4-6 Composition of the load moment limiter**

The load moment limiter is a computer system for controlling and monitoring mobile cranes.

The load moment limiter calculates data from pressure sensors, length sensor, angle sensor and other monitoring devices to judge whether the crane is in safe working conditions, and displays the basic parameters, such as boom length, boom angle, working radius, rated lifting capacity, engine RPM and fuel reserve etc., on the LCD.

If the actual load reaches 90% – 100% of the rated one, the warning light lights up and the buzzer sends out slow acoustic warning. At this time, the operator should pay much attention to the operation.

If the actual load reaches 100% of the rated one, the warning light lights up and the buzzer sends out fast acoustic warning and all dangerous crane movements are switched off.

#### CAUTION

- (1) **The load moment limiter can prevent the crane from toppling or boom destructed and personnel death and injuries, thus ensuring safe operation of the crane. However, do not rely entirely on the load moment limiter. If the rated lifting capacity displayed on the load moment limiter is different from the one shown in the lifting**

capacity table, obey the lifting capacity table.

- (2) Make sure that the load moment limiter is set to the proper configuration before operation. It is dangerous to set the load moment limiter incorrectly. Only the operator who is skillful at operating this crane and system can set the OM. In normal situations, make sure that the load moment limiter is set to match the crane actual OM.
- (3) The load moment limiter should only be commissioned by service technician!



**Figure 4-7 Load moment limiter screen**

The icons in the load moment limiter's main interface represent the following:

- F1: operating mode (OM) selection;
- F2: Fine adjustment;
- F3: Calibration
- F4: Maintenance
- F5: Simulation wall;
- F6: Query
- F7 Engine data (non-road stage IV)
- F7-F8: reserved
- F9: Volume
- F10: System setting

For details, please refer to operating instructions attached to the crane.

### 4.3 Adjustment of crane operator's seat

- a) Vertical adjustment of headrest:

As shown in Figure 4-8, the height of the headrest is adjusted manually.

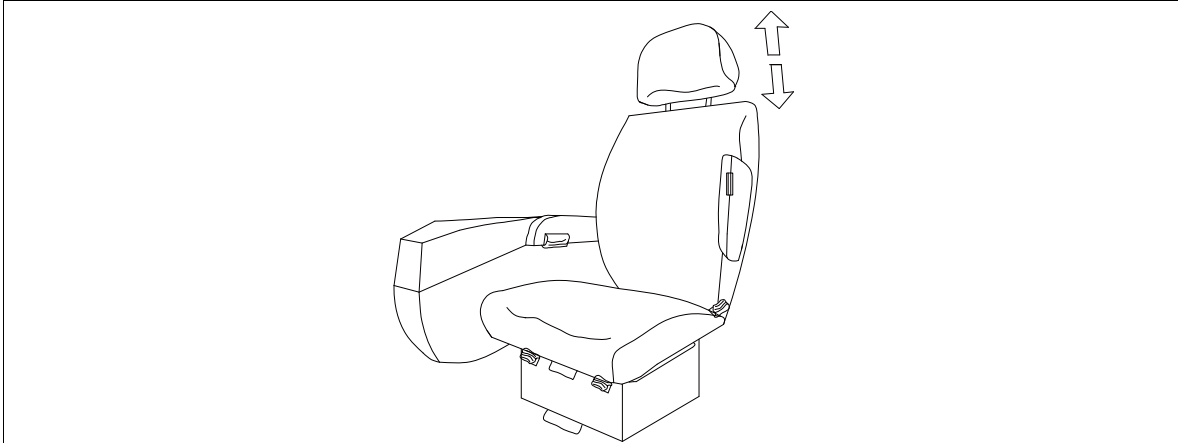

**Figure 4-8 Vertical adjustment of headrest**

- b) Adjustment of armrest:

As shown in Figure 4-9, the height of the armrests can be adjusted by adjusting the knobs.

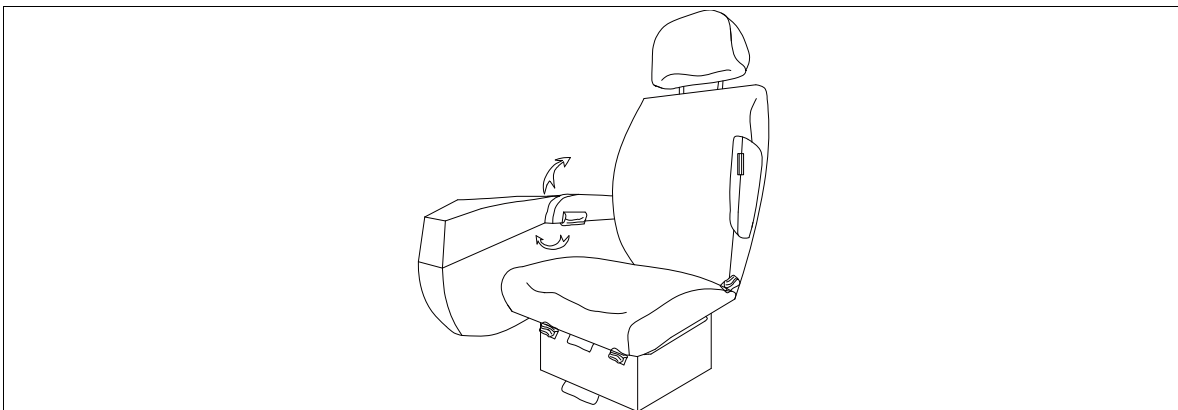

**Figure 4-9 Adjustment of armrest**

- c) Horizontal adjustment of the seat:

As shown in Figure 4-10,

Pull the lever upwards;

Move the seat to required position;

Release the lever.

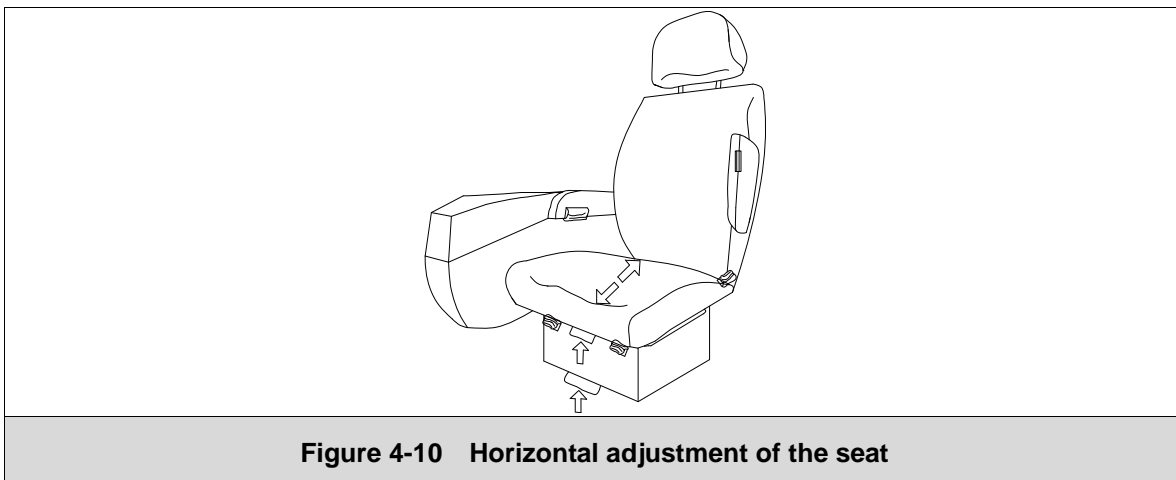

d) Adjustment of the height of the seat:

As shown in Figure 4-11, there are two levers to adjust the height of the seat. The front lever adjusts the height of the front of the seat, and the rear lever adjusts the height of the rear of the seat.

Pull the front lever upwards, the height of the front of the seat increases.

Pull the rear lever upwards, the height of the rear of the seat increases.

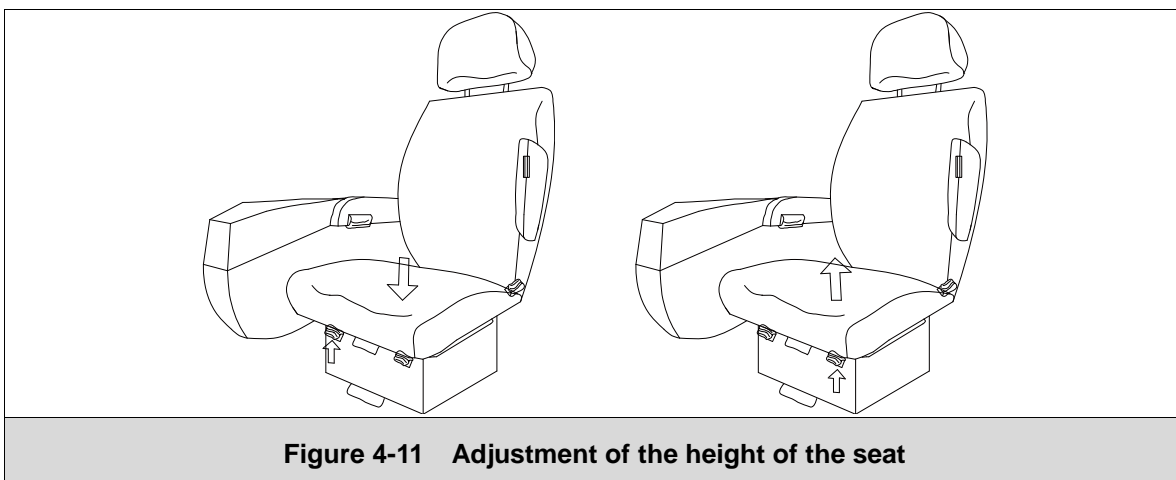

e) Adjustment of the backrest:

As shown Figure 4-12,

Press your back gently against the backrest;

Pull the lever upwards;

The backrest tilts backwards.

Pull the lever downwards;

The backrest automatically tilts forwards.



**Figure 4-12 Adjustment of the backrest**

## 4.4 Startup of the crane

### 4.4.1 Check the general conditions of the crane before startup

Before starting up the crane, the operator should ensure that the following conditions are fulfilled:

- a) The crane is horizontally aligned, and the boom is located in front center area.
- b) The toothed gear of the slewing bearing is clean and greased.
- c) The slewing retaining pins have been pulled out.
- d) Check overall levelness of the crane.
- e) The air inlet of hydraulic oil tank is not blocked.
- f) All covers on the sides are closed and locked.
- g) No person or object is within the slewing radius of the crane.
- h) Make sure that wire rope, winding drum and limit switches are free of ice or snow.
- i) There is no loose part on the slewing platform or on the boom.
- j) The shutoff valve near the hydraulic oil tank is opened.
- k) Check engine oil level.
- l) Check the oil level in hydraulic oil tank.
- m) Check the oil filter on hydraulic oil tank.
- n) The coolant is added to the specific position.
- o) The battery master switch is in ON position.

#### **DANGER**

- (1) **Never check the coolant level if the engine is still warm. To check it, the engine must be cooled down. Otherwise, there is the danger of serious skin burns.**
- (2) **Before carrying out any boom movements, ensure that there are no loose parts on the boom such as pins, retaining spring or ice. If this is not ensured, there is a danger of accidents due to these objects falling off and striking persons or other objects on the ground.**

#### **CAUTION**

**The inclination range for the superstructure: the inclination should be less than 1% in both lateral direction and longitudinal direction. If this range is exceeded, the crane operator must adjust the crane to horizontal position.**



Figure 4-13 The overall inclination angle indication

### 4.4.2 Turn on power supply

As shown in Figure 4-14, insert the ignition key into the ignition lock (position 2 in Figure 4-14) and turn it clockwise to the 1<sup>st</sup> position, and the power supply is turned on.



Figure 4-14 Ignition start key switch

### 4.4.3 Air conditioner

The air conditioning system in the cab is capable of both heating & cooling. Its control panel as shown in Figure 4-15 is located on the upper right side of the cab.

Heating:

- Check if the ball valve near the engine is opened;
- Turn the mode selection switch to "Heating" position, the heating indicator light lights up at this time;
- Adjust the air volume switch to obtain desired temperature.

Cooling:

- Check if the ball valve near the engine is closed;
- Turn the mode selection switch to "Cooling" position, the cooling indicator light lights up at this time;
- Adjust the air volume switch to obtain desired temperature.

The fresh air switch can be turned on when indoor and outdoor air circulation is needed.



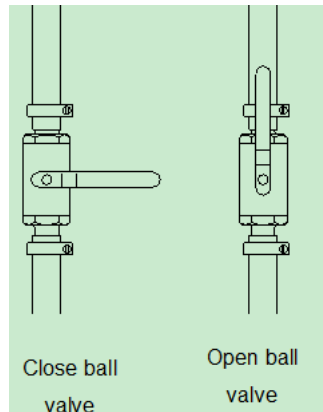

Figure 4-15 AC control

No.	Part	Description
1	Heating rotary switch	To turn on the heating
2	Cooling rotary switch	To turn on the cooling
3	Wind speed switch	Rotate it to adjust wind outlet speed

### 4.4.4 Checks before engine start

#### 4.4.4.1 Check the function switches in the cab

- a) Check if all control levers are in neutral positions.
- b) Check if the switches on the control panel are returned to original status.
- c) Check if the emergency stop button is returned to original position.

#### 4.4.4.2 Check signals and warning indication when crane is in work status

After the power supply of the crane is turned on, the interface shown in Figure 4-13 appears in the load moment limiter's screen, in which following parameters are included:

- a) Fuel level
- b) Whether each winch is overwinded.
- c) Maximum main boom angle
- d) Inclination angle of the whole crane.



Figure 4-16 Check of signals and warning indication

#### 4.4.4.3 Check load moment limiter

- Check if the load moment limiter works properly.
- Check if current boom configuration is correctly set.
- Confirm that the crane is not overloaded.
- Check current wind speed (optional).



Figure 4-17 OM selection

#### 4.4.5 Start the engine

After the power supply is turned on, insert the key into the key lock (position 2 in Figure 4-18) continue to turn the ignition key clockwise to 2<sup>nd</sup> position so as to start the engine.

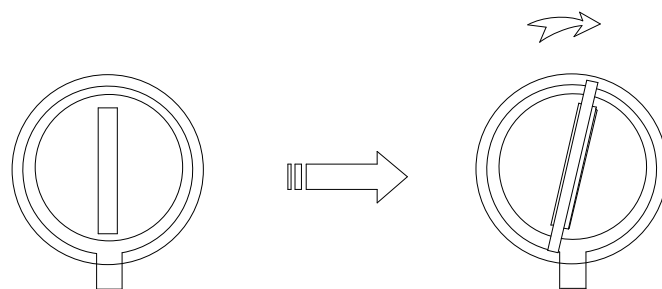

Figure 4-18 Start engine via ignition start switch

After the engine is started, the following parameters should be checked to ensure that the engine works properly. Refer to Figure 4-19.



**Figure 4-19 Check engine parameters**

- Check if engine rotational speed is normal.
- Check if engine oil pressure is normal.
- Check if engine coolant temperature is normal.
- If there is fault information displayed in the main interface, press F6 to check current fault, as shown in Figure 4-20.



### ! CAUTION

- (1) Compared with routine conditions, it takes longer time to preheat the engine automatically in cold temperature. This is a normal phenomenon.
- (2) Do not use accelerator when starting the engine.
  - If the engine fails to start after approx. 5s, slowly depress the accelerator pedal all the way down.
  - If the engine cannot be started within 5-10s, give up the starting attempt and wait approx. 1 minute before trying again.
  - If the engine still cannot be started for three attempts in a row, stop starting the engine at once and check it for fault.
  - If the temperature of engine is high, do not depress accelerator pedal when starting the engine to avoid black smoke discharging.
  - After the engine starts, release ignition key at once to let it return to initial position, and check the parameters of the engine at the same time.
- (3) The engine cannot work with full load until the running temperature is reached.

## 4.5 Safety devices

The crane operator must check all safety devices for functional work before every crane operation.



**Operating crane with faulty and incomplete safety devices is prohibited!**

### 4.5.1 Emergency stop button

The emergency stop button is located under the front left windshield glass in the operator's cab. As soon as this emergency stop button is pressed,

- The power supply of complete vehicle is switched off,
- The engine stops,
- All crane movements stop immediately.



Figure 4-21 Emergency stop button



**The emergency stop button must only be used in case of an emergency and not as a normal procedure for shutting down the diesel engine!**

**If an emergency stop is triggered while a load is being lifted, there may be a risk of accident owing to swinging of the load.**

### 4.5.2 Battery master switch

The battery master switch is installed at the side of the batteries.

Set battery master switch in "OFF" position for long crane so as to prevent the electricity of battery from discharging excessively.

The battery master switch is shown in Figure 4-22.

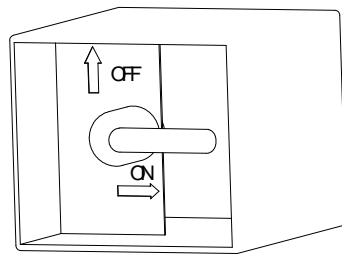

**Figure 4-22 Battery master switch**

### 4.5.3 Power supply indicator light

When the ignition start switch is in the 1<sup>st</sup> position, this indicator light illuminates. It is located at the upper right position of the cab.

### 4.5.4 Lowering limit switch

In order to prevent the wire rope from being spooled up automatically after being reeled off completely, the lowering limit switches installed on the winches will automatically switch off the movements “Reel winches off” if there are only 3 wraps of rope on the winches. In this case, the warning light lights up, the buzzer sounds alarm and only the upward movement of the hook is permitted. During commissioning and maintenance, activate the lowering limit bypass switch to bypass the switch-off. Refer to Figure 4-23.



**Do not use the bypass key switch during usual crane operations.**

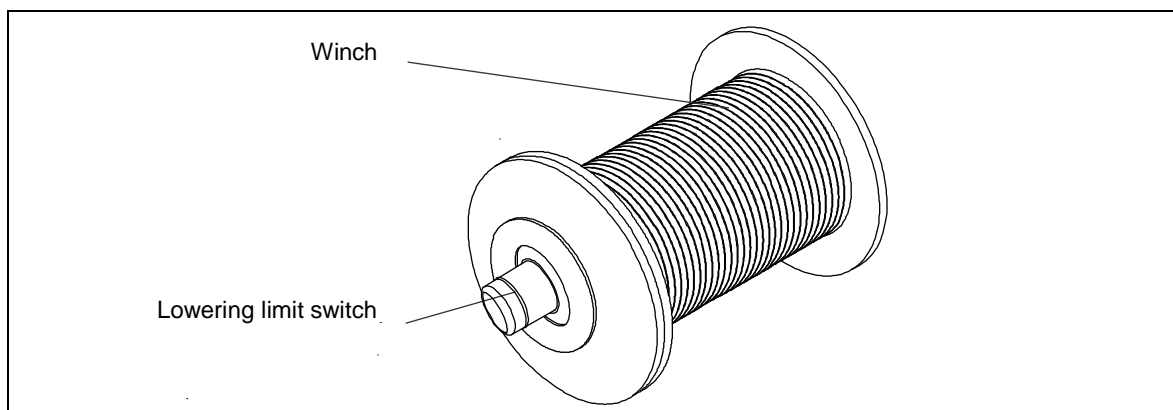

**Figure 4-23 Lowering limit switch**

### 4.5.5 Hoisting limit switch

The hoisting limit switches on the main boom, jib and rooster sheave are intended to prevent the hook block from colliding with the rope pulley.

When the distance detected between the hook block and the pulley is less than the safety one, the hoisting limit switch is triggered and buzzer sounds. The crane movements "Spool winches up", "Derrick down" and "Telescope out" are switched off. At this time, only the crane movements "Reel off winches", "Derrick up" and "Telescope in" can be switched on. Refer to Figure 4-19.

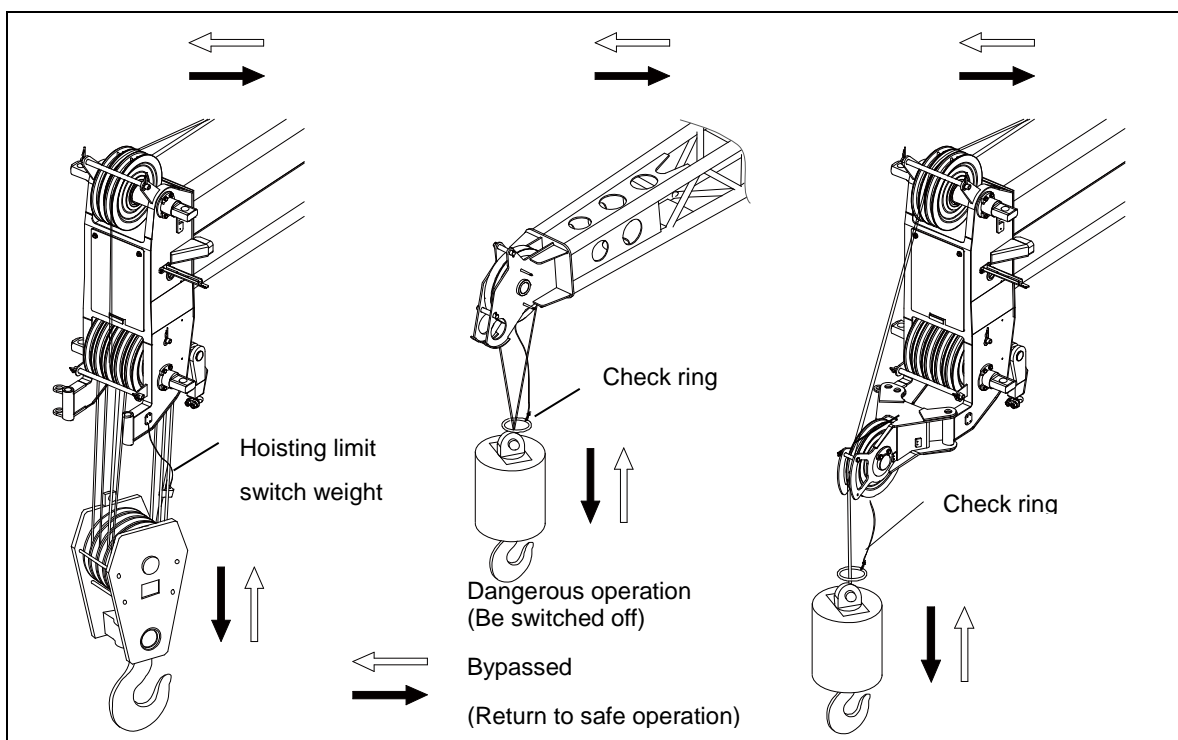

Figure 4-24 Hoisting limit switch

### 4.5.6 Levelness indication

This crawler crane is installed with an electric levelness gauge, which can monitor real-time crane levelness and display the value in the LML screen.

## 4.6 Crane operation

### 4.6.1 Requirements before operation

- a) The boom and rear counterweight have been assembled according to lifting capacity tables, and the crawler carriers are extended completely.
- b) The gradient of the ground is less than 1%, and the ground has sufficient load bearing capacity.
- c) The diesel engine is running.
- d) The wire rope is properly reeved through rope pulleys on the boom head and hook block.
- e) All safety devices are set according to lifting capacity charts and can work normally.
- f) Nobody or no object is within the danger zone.



- (1) **Carefully and slowly operating the crane can not only extend the service life of the crane, but also avoid accidents.**
- (2) **Ensure that no object or person is within the danger zone during crane operation.**
- (3) **At least an acoustic signal should be given before each crane operation.**

### 4.6.2 Checks during crane operation

- a) If any of the alarms mentioned in section 4.2 is sent out during crane operation, it is necessary to stop the operation immediately and shut down the engine to check the corresponding mechanism and eliminate the fault in time.
- b) In the course of operation, always check indications on the load moment limiter and observe the load condition at any time. In case of an overload or other alarms, it is necessary to immediately stop the operation for inspection and eliminate the fault in time.
- c) When the crane works at night, please turn on the master lighting switch and work floodlight switch so as to facilitate the operation of the operator and remind other people around the crane.

### 4.6.3 Setting of boom configuration

As to specific setting procedures, please refer to *Load Moment Limiter Operating Manual*.

#### 4.6.4 Operation of travel gear

The travel movements are controlled by left and right travel gear pedals or left and right hand levers. The movements “left crawler forwards” and “left crawler backwards” are controlled by the left travel gear pedal or left hand lever, and the movements “right crawler forwards” and “right crawler backwards” are controlled by the right travel gear pedal or right hand lever.

The traveling alarm device, which is installed at the bottom of the cab, will send out an acoustic alarm during traveling.

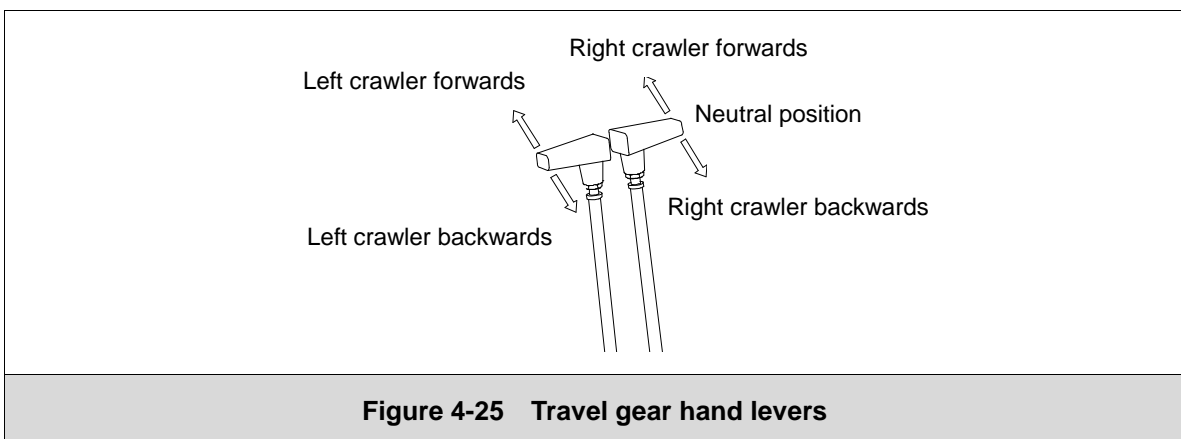

**Figure 4-25 Travel gear hand levers**

##### a) Traveling on level ground

The crane can carry out such traveling movements as traveling straight ahead / backwards, turning to left with a crawler, turning to right with a crawler and differential steering as well as turning on the spot on level ground. The operator can carry out corresponding operation according to actual work conditions.

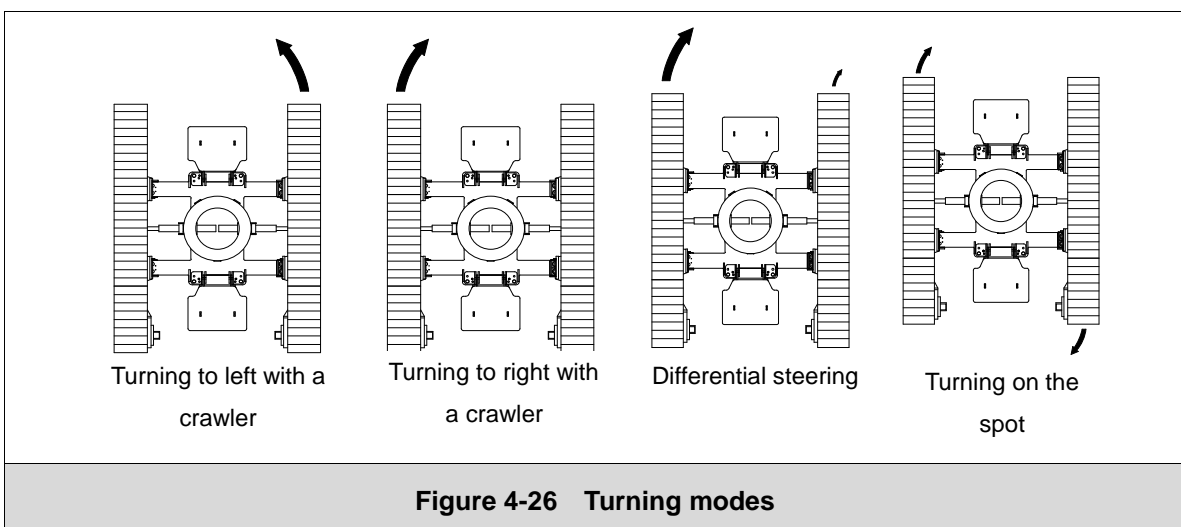

**Figure 4-26 Turning modes**

### CAUTION

- (1) When there is a need to stop traveling or steering, return the travel gear pedal or hand lever to neutral (zero) position, the traveling brake will be applied automatically.
- (2) When this crane is traveling with load for a long distance, ensure that the boom is located straight ahead and the traveling reducer is behind the slewing platform. When the load lifted exceeds 50% of the rated lifting capacity, the slewing locking device should be locked by pressing the slewing lock button on the right joystick. Press the button again to unlock the slewing platform.
- (3) When travelling with or without a load, do not compound other superstructure movements or conduct other crane operations.
- (4) Turning with a suspended load is prohibited in principle. If such operation is needed, turn at a very low speed, and maintain a sufficient turning radius, so as to avoid crane vibration.

#### b) Traveling on slope

When the crane is traveling on slope, the slewing control lever is placed in neutral (zero) position.

When the crane is traveling uphill, the engine speed should be controlled within medium speed range.

When the crane is traveling on a slope with maximum permissible gradient, it can only be fitted with basic boom, the counterweight points to the uphill and the drive sprocket points to the downhill. When the crane is traveling downhill, the drive sprocket shall points to the uphill.

If the crawler crane needs to turn on the slope when it is traveling uphill, some treatments should be taken to the undulations to form a gentle slope curve (see Figure 4-27), which can prevent crane's center of gravity from deviating and the load from concentrating on a section of crawler when the crawler crane is traveling over undulations.

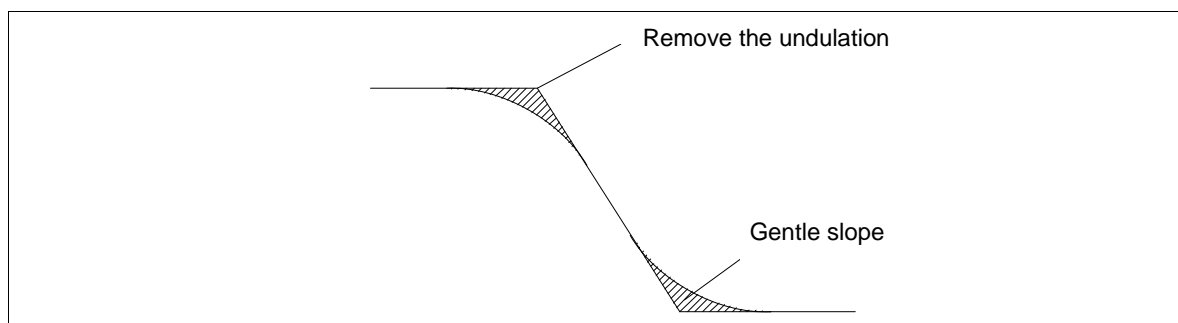

**Figure 4-27 Slope treatment**



- (1) When the crane is traveling from the horizontal ground to the slope, if its center of gravity deviates forwards, the crane must be stopped to adjust the center of gravity.
- (2) When the crawler crane is traveling on a slope with rated gradient, if the ground condition is unclear, the counterweight and boom should be dismantled from the crane during traveling so as to assure safety.
- (3) The crane can travel with a suspended load, providing that the following precautions are taken:
  - a) The ground that supports the crane must be flat without any gradient.
  - b) The subsoil must be capable of bearing crane's maximum service weight and the weight of suspended load.
  - c) The boom should be located straight ahead and only the lowest traveling speed is allowed.
  - d) Jerky crane movements should be avoided.
  - e) The suspended load should be lashed to prevent it from swinging.
  - f) Steering by using the crawler is prohibited.
  - g) Travelling on a slope whose gradient exceeds 8° is prohibited.

#### 4.6.5 Telescoping operation

The main boom has five parts to it: one basic boom section and four telescopic sections. The basic boom is fixed with the slewing platform while the four telescopic sections can telescope simultaneously to realize different boom length.

To extend and retract the boom, a telescoping system is attached in the boom structure. The components of the telescoping system are as follows:

- Telescoping cylinders
- Boom extension ropes
- Boom retraction ropes.

The movements "Telescope boom in / out" are controlled by two telescoping cylinders and the wire ropes used together.

Figure 4-28 shows the telescoping principle:

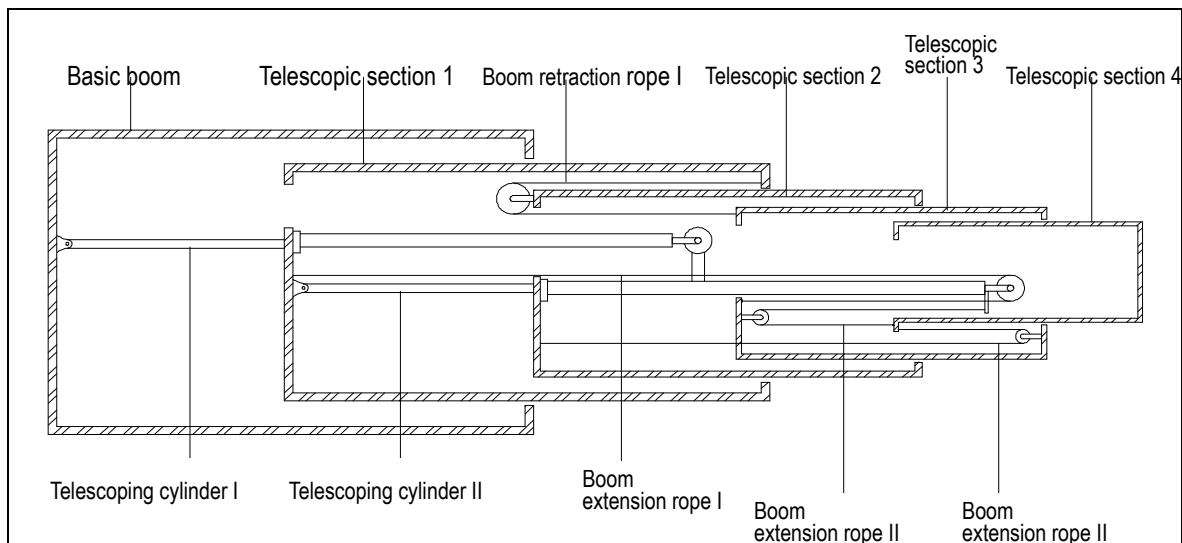

**Figure 4-28 Telescoping**

The length sensor installed at the left side of the main boom is used to measure real-time boom length and transmit the length information to the load moment limiter. The boom length is displayed in the load moment limiter's screen in real-time.

### 4.6.5.1 Main boom telescoping operation

The right joystick controls telescoping of the main boom. When the joystick is pushed leftward, the main boom is telescoped in; when it is pushed rightward, the main boom is telescoped out.

#### CAUTION

1. When the main boom is telescoped in/out, the hook will be lifted or lowered naturally. Therefore adjust the height of the hook using the hoisting joystick when telescoping the main boom. Operate smoothly and stably at a low speed.
2. Telescoping speed can be adjusted using the accelerator pedal or the right joystick. Increase the depressing force onto the accelerator pedal or toggle the right joystick to a larger angle to increase the telescoping speed.
3. Do not telescope out the main boom immediately after it has been telescoped in. Wait 2 s before such operation;
4. Only hoist the load vertically and do not drag or tow a load which still sits on the ground, so as to avoid lateral load;
5. The bypass switch can only be used for commissioning or repair, and is prohibited for use during normal operations;
6. After the main boom is telescoped out, it may telescope in/out a little bit due to temperature change of hydraulic oil. This natural telescoping in/out is also subject to

influence of other factors such as boom angle and lubrication condition, etc.

7. To avoid the aforementioned telescoping in/out, maintain a moderate hydraulic oil temperature. Telescope the main boom to offset such shift and resume target boom length.

8. It is strictly prohibited to telescope the main boom with a suspended load.

#### 4.6.6 Derricking operation

The boom angle is changed by telescoping in/out of the derricking cylinder, as a result of which the working radius is varied. The boom angle can be changed within  $-1.5^{\circ}$ - $80^{\circ}$ . The boom angle of  $-1.5^{\circ}$  provides great convenience during jib installation, reeving change and component maintenance at the boom head. The derricking balance valve installed in the hydraulic system can not only ensure stable and smooth boom derricking movements, but also maintain the boom at a specified length.

The derricking operation is controlled by the right joystick, as shown in Figure 4-29.

Derricking speed can be adjusted using the accelerator pedal and the right joystick. Increase the depressing force onto the accelerator pedal and toggle the right joystick to a larger angle to increase the derricking speed.

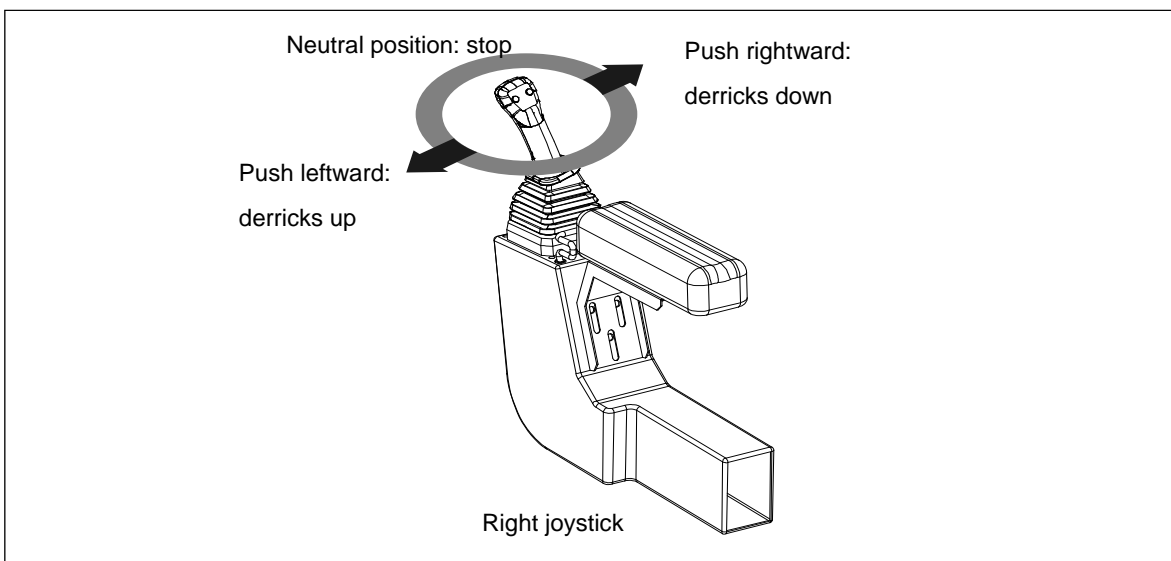

Figure 4-29 Derricking control

- (1) Conduct all derricking movements smoothly. You can cause damage to the crane if you move the load up or down with quick stops.
- (2) The derricking angle and working radius should be restricted according to the lifting capacity tables, so as to avoid crane overloading or tip-over due to increased working radius.

#### 4.6.7 Lifting and lowering operation

The hoisting mechanism consists of a hydraulic motor, winch reducer, brake, hoisting limit switch, lowering limit switch, wire rope, main hook and auxiliary hook, etc.

The hoisting mechanism can be divided into the main winch part and the auxiliary winch part.

The joysticks for controlling the two winches are located in the driver's cab. The right joystick is used to control the main winch, while the left joystick is used to control the auxiliary winch.

The left and right joysticks are as shown in Figure 4-30.

#### NOTICE

**Consult the lifting capacity tables and lifting height chart before conducting hoisting operations.**



Left joystick

Right joystick

**Figure 4-30 Joysticks for controlling the main and auxiliary winches**

#### ! WARNING

**1. For a crawler crane configured with an optional safety switch, the joysticks can only become operational after the safety switch is pressed.**

#### 4.6.7.1 Rated capacity charts and lifting height chart

##### a) Rated capacity charts

How to consult a rated lifting capacity:

First find the suitable boom length and working radius in the lifting height chart, and then find the rated lifting capacity by the two values in the lifting capacity tables.

### NOTICE

**When the jib is installed for a lifting operation, find the correct rated lifting capacity according to main boom angle in the rated capacity charts.**

For example: when a full-weight counterweight is installed and the main boom is used for lifting operation, find the rated lifting capacity according to the method as shown in Figure 4-31.

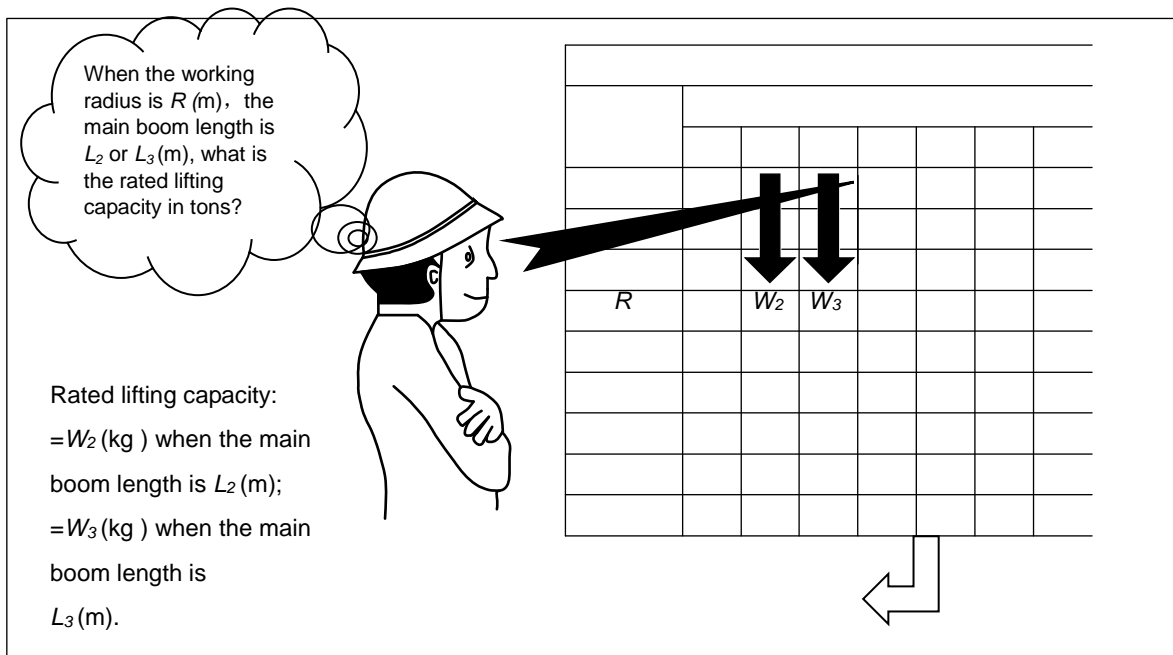

Figure 4-31 Consulting the lifting capacity table



**Confirm the rated lifting capacity according to the actual working conditions in the rated capacity charts.**

b) Refer to Figure 4-32 for the lifting height chart.

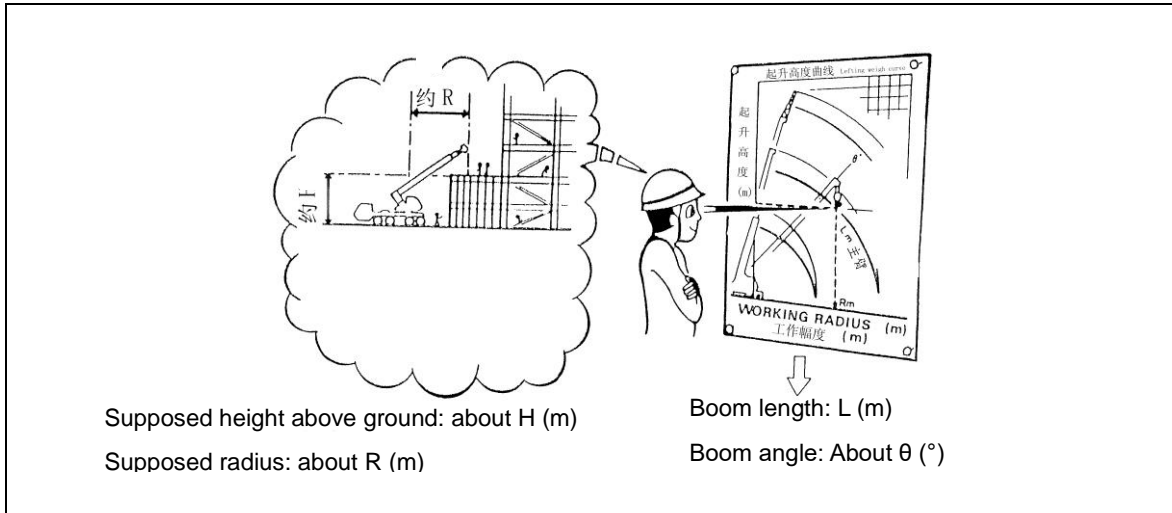

Figure 4-32 Look up lifting capacity



**All the working radius and lifting height in lifting height charts do not include the deflection of main boom and jib.**

c) Working radius

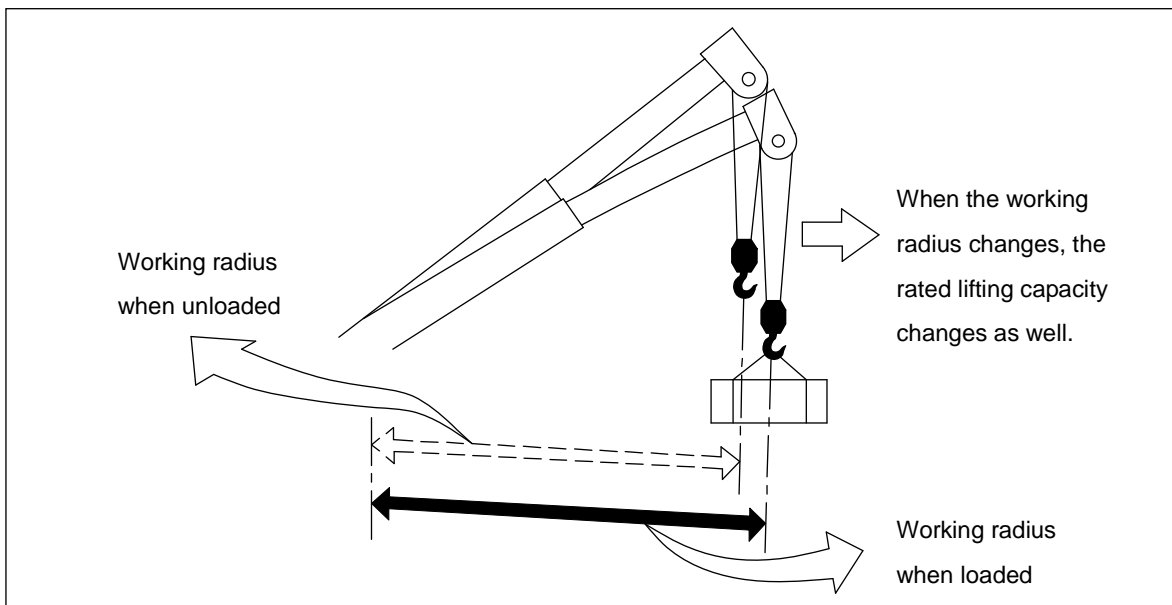

Figure 4-33 Working radius

A balance valve is installed in the hoisting mechanism, which can not only ensure stable and smooth lifting and lowering, but also maintain the load to a specified height.

When the main boom is telescoped out and the lifting height is increased, the length of the wire

rope may become insufficient. Change the reeving of the wire rope to solve such problem. Install the height limiting limit weight during the change process.

#### 4.6.7.2 Main hoist mechanism operation

The main winch is controlled by the right joystick.

Pull the right joystick slowly backward to spool up the hook;

Push the right joystick slowly forward to reel off the hook, as shown in Figure 4-29.

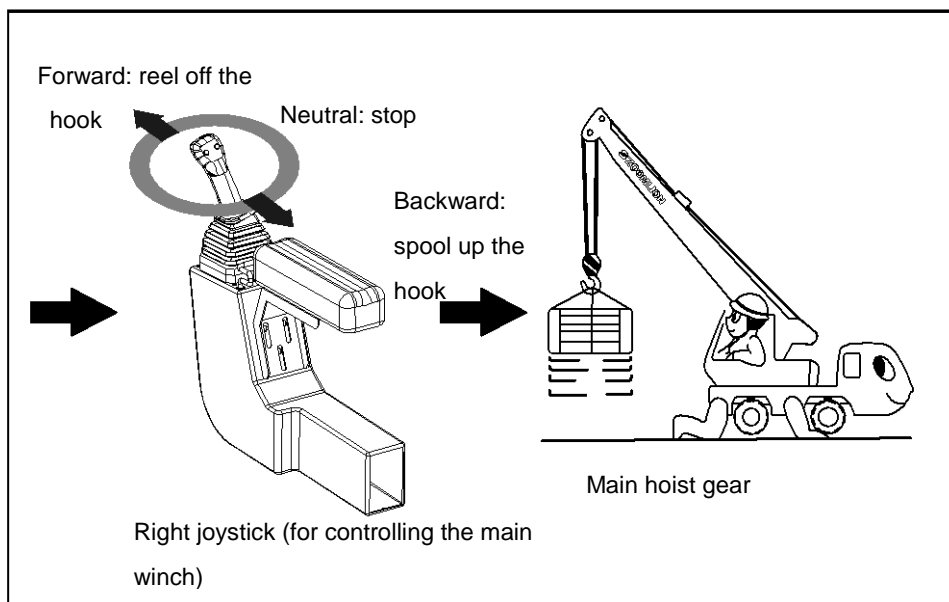

Figure 4-34 Main hoist gear – right joystick

#### ! WARNING

1. For a crawler crane configured with an optional safety switch, the joysticks can only become operational after the safety switch is pressed.

- To align the boom with the load:
  - a) Press the free swing button on the joystick to activate the free swing function, and the free swing indicator light illuminates.
  - b) The boom will automatically swing to the upper right position of the load.
  - c) After the two are aligned, press the free swing button again to deactivate the function, and the indicator light goes off.

### 4.6.7.3 Auxiliary hoist mechanism operation

The main winch is controlled by the left joystick.

Pull the left joystick slowly backward to spool up the hook;

Push the left joystick slowly forward to reel off the hook, as shown in Figure 4-35.

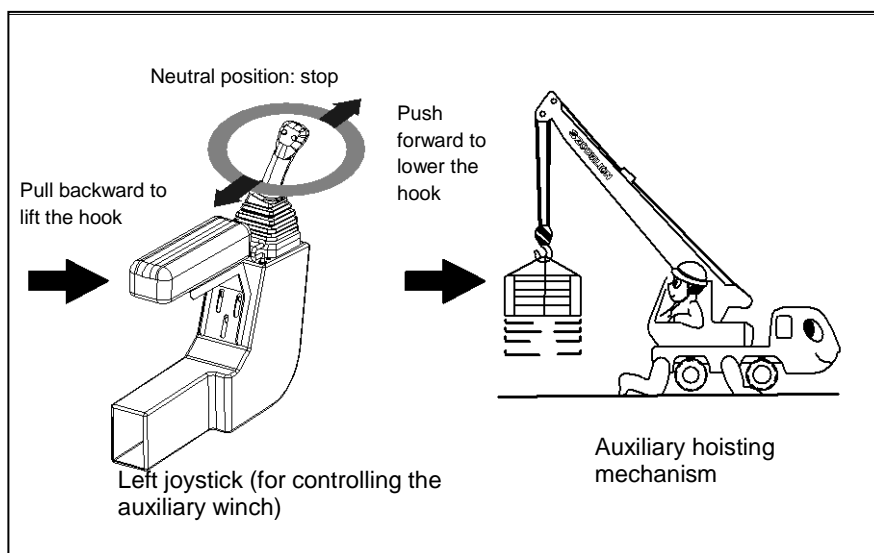

Figure 4-35 Auxiliary hoist mechanism – right joystick

#### ⚠ WARNING

**1. For a crawler crane configured with an optional safety switch, the joysticks can only become operational after the safety switch is pressed.**

After the operation is completed, release the joystick to its neutral position to stop the hoist mechanism.

Lifting speed can be adjusted by using the high/slow speed pre-selection switch on the control panel, the accelerator pedal, or the right joystick. Selection of the high speed mode, depressing of the accelerator pedal, or increase of the inclination angle of the right joystick can increase the lifting speed.

Note: the operation principle of both the left and right joysticks is identical.

When the hoist mechanism is overwinded or overloaded, the system will give acoustic and visual alarm and cut off further lifting, boom extension or derricking-down movements.

When the wire rope reaches its lowering limit, the system will cut off further reeling-off movements.

The aforementioned limitations can only be bypassed by using the bypass switch during commissioning and repair mode. Operate with great caution when the bypass switch is used to permit further movements into a dangerous direction.



It is strictly prohibited to use the bypass switch during normal crane operations.



- (1) Select suitable reeving of the wire rope according to boom length and load to be lifted. If the hook rotates due to twisted wire rope, lower the load onto the ground, and then straighten the wire rope before lifting it again.
- (2) Pay close attention to the remaining number of wraps of the wire rope on the drum when lifting a load or lowering a load into a deep pit. There should always be more than 3 wraps left on the drum.
- (3) Lift the load vertically. Do not drag the load that is still on the ground. Do not pull it at an angle.
- (4) At beginning of a lifting operation, first lift the load off the ground by a small height and confirm that there is no risk of potential danger before conducting further lifting.
- (5) When the load is still in contact with the ground, do not lift it further with compound movements of derricking-up and telescoping-out.
- (6) Do not change abruptly between "Reel off" and "Spool up". Return to the neutral position first before changing operation direction. Otherwise, the machine will be damaged.
- (7) The slings must be of enough strength.
- (8) Do not use the crane to lift personnel.

#### 4.6.8 Slewing operation

##### 4.6.8.1 Slewing mechanism

The slewing mechanism consists of a hydraulic motor, planetary gear reducer, slewing bearing, and slewing locking device, etc. It provides the superstructure with the capability to slew in an unlimited 360° range.

##### 4.6.8.2 Slewing locking device

This crane adopts a manual slewing locking device, which can lock up the superstructure in four directions, as shown in Figure 4-36.

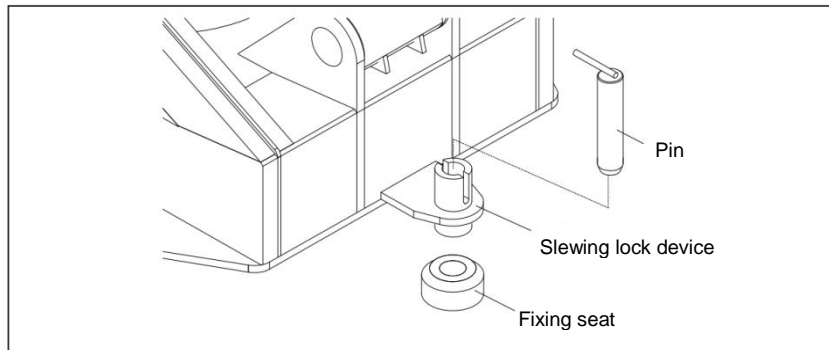

**Figure 4-36 Slewing mechanism**

**! CAUTION**

As the operator's rear and side vision is greatly limited during slewing process, ring the horn to alarm personnel standing in the slewing range and ensure that there is no obstacle within the range, so as to ensure operation safety.

**4.6.8.3 Slewing movements**

First ensure that the slewing locking device is unlocked.

Slewing is controlled by the left joystick. Slewing speed can be increased by depressing of the accelerator pedal or larger toggling angle of the left joystick.

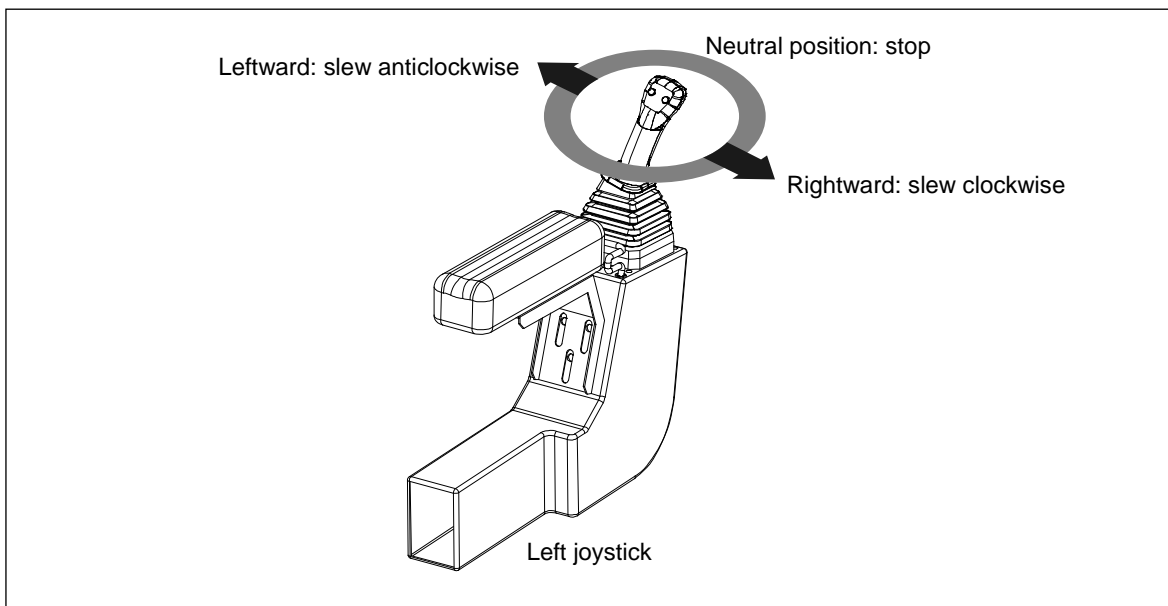

**Figure 4-37 Slewing operation**

**! WARNING**

1. For a crawler crane configured with an optional safety switch, the joysticks can only become operational after the safety switch is pressed.

**! CAUTION**

1. Operate slewing in a stable way and avoid abrupt change of operational direction which is dangerous;
2. For working safety, check fastening condition of the slewing bolts after the crane has been put into use for the first 100 hours. Fasten them by a tightening torque of 900 N.m (700 lbf-ft). After the first 500 working hours are reached, check their fastening condition again. Conduct such check every 1000 working hours thereafter;
3. This crane is capable of slewing with a load. However it is strictly prohibited to drag a load which is still sit on the ground transversally;
4. Check if the left and right crawler beams have been extended to their maximum trip.
5. Prepare enough working space for the slewing;
6. Confirm that the slewing locking mechanism is unlocked before operating slewing. Check if the device is locked when the crane is not used.

#### 4.6.9 Free swing operation

The free swing button can be used to align the hook with the vertical line of center of gravity of a load by activating free swing movement of the slewing platform. It can decrease lateral force applied to be main boom and therefore prevent its damage. When the wire rope is in vertical status, stop the free swing movement.

**! CAUTION**

1. Send out an alarm before operating slewing of the crane;
2. Overspeed slewing may increase probability of accidents;
3. Ensure that there is no obstacle within the slewing range before operation, otherwise there is a risk of accident.
4. When the boom length or weight of load is large, slew in a low speed.
5. Check levelness of the ground within the slewing range before operating slewing.
6. Pressing of the free swing button and toggling of the left joystick to spool up the hook should be conducted simultaneously, so as to apply a lateral force onto the wire rope to enable the hook to align with the vertical center of gravity of the load to be lifted.

#### 4.6.10 Crawler carrier extending

The switch controlling extension and retraction of crawler carriers is located in the left control panel in the driver's cab, as shown in Position 3 in Figure 4-38.



**Figure 4-38 Position of switch for controlling crawler carrier extension and retraction**

Procedure for extending crawler carriers:

- When the crane arrives at the operating site, first check the surrounding environment and confirm whether the crawler carriers can be extended.
- Pull out the securing pins (four pieces in total) of outrigger beams of outriggers and insert stopping blocks to maintain levelness of the outriggers and undercarriage. Pull out the limiting pin connecting the horizontal plate (four pieces in total) and the undercarriage. Make sure that the left and right crawler carriers can be extended.
- Turn on the pre-selection switch of crawler horizontal cylinder first to enable extension of the crawler carriers through pressurized oil from the hydraulic system.
- Insert the limit pins between horizontal anchoring rods and undercarriage central section after the crawler carriers are extended completely, so that the undercarriage central section and crawler carriers are locked relatively.
- Retraction of the crawler carriers is conducted in similar steps, except the horizontal cylinder telescoping switch is turned to the opposite side.

 **WARNING**

- (1) In any cases, extension and retraction of crawler carriers must be carried out by more than two operators. During operation, one operator performs the crawler carrier extension and retraction operation, while the other operator checks if crawler carriers have extended or retracted to proper position.
- (2) Ensure that the limit pins between horizontal anchoring rods and undercarriage central section are inserted well after crawler carriers are extended or retracted to proper positions.
- (3) Do not operate crawler carrier extension and retraction mechanism when the crane is fitted with the boom and counterweight or it is lifting a load.
- (4) The engine speed must be controlled within middle-low speed (about 1000 rpm-1500 rpm) when crawler carriers are extended and retracted.
- (5) The extension and retraction of crawler carriers must be carried out on the firm and flat ground. Pay attention to the level state of the machine during operation.
- (6) Do not do lifting operation before the crawler carriers are extended completely.

### 4.7 Change of reeving

Before changing the wire rope reevings:

- Support the crane on outriggers.
- Fully retract the boom and move it to the side or rear of the crane.

Refer to Figure 4-39

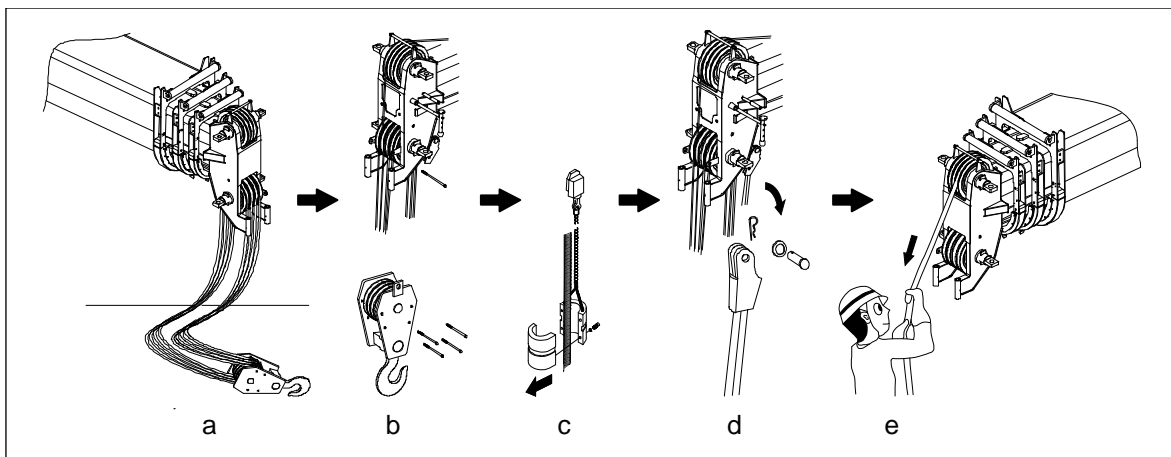

**Figure 4-39 Rope reeving**

Change the wire rope reevings as follows:

- a) Derrick the boom down and put the hook on the ground.
- b) Remove the pins on the hook block and boom head to take the wire rope out.
- c) Remove the hoisting limit switch weight.
- d) Remove the rope lock.

Note: when the rope reeving is an odd number, the rope lock is fixe onto the hook; when it is an even number, the rope lock is fixed onto the boom head.

- e) Change rope reevings.

## NOTICE

1. The installation position of the hoisting limit switch weight is different for an odd reeving number and an even reeving number, as shown in Figure 4-40.

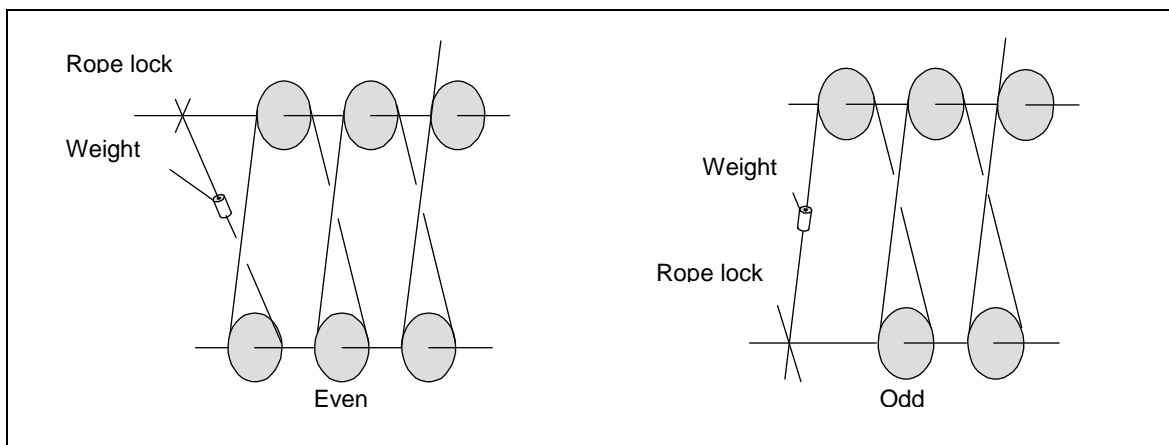

**Figure 4-40** Location of hoisting limit switch weight

2. Reeve the wire rope in sequence and avoid messing it up;
3. Install the rope lock and rope clamp as shown in Figure 4-41.
4. Do not fixed the movable end of the wire rope onto the rope clamp.

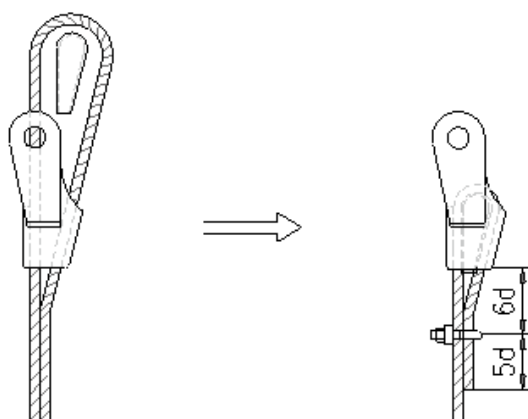

**Figure 4-41** Rope lock and rope clamp



# **ZOOMLION**

## **Operator's Manual for Telescopic Crawler Crane**

### **Chapter 5 Assembly and Dismantling**





## Chapter 5 Assembly and Dismantling

### 5.1 Safety-technical notes

#### 5.1.1 Notes on assembly

- a) Make sure that the crane complies with operating requirements.
- b) Reeve the hoisting rope through the boom head using a suitable rope reeving.
- c) For assembly work on the crane, a safe assembly support or working platform should be used. Improvisations are prohibited. Otherwise, there is a danger of falling down.
- d) Remove obstacles away from the ground on the site before assembling and dismantling. In addition, the ground on the site should be cordoned off to prevent access by unauthorized person.
- e) Before derricking up the boom, choose flat ground to support the crane.

#### 5.1.2 Checking safety measures

- a) Clearly define the duty and area of responsibility of all personnel concerned.
- b) Check whether there is sufficient safety clearance to slopes and trenches.
- c) Check whether there are any live wires within the operating range of the crane. Make sure that there is enough distance between the crane and live wire so that any components of the crane will not come into contact with the live wire when crane movement is carried out.
- d) Check whether an appropriate operating site has been selected so that the crane movements can be performed within maximum and minimum working radiuses.
- e) Check whether there are obstacles which will hinder required crane operation.
- f) Check whether the ground can provide adequate load-bearing capacity.
- g) Know clearly about the type of crane operation and operating mode.
- h) Distance between the lifting points and surrounding buildings.
- i) Influence of communal facilities on crane operation (including the overhead high/low voltage lines and underground gas pipes).
- j) Movement restrictions due to surrounding structures (e.g. is there another crane nearby in working).
- k) Number, weight, dimensions, material of load(s) to be lifted.
- l) Required lifting height and slewing radius.
- m) Heights and widths of thoroughfares leading to the site.
- n) Check the use of radios adopted by signalman and crane operator.
- o) Take appropriate measures to keep people and equipment unconcerned away from the danger area of the crane.



To master the actual condition of lifting operation accurately and ensure safe operation, the safety measures mentioned above should be checked and a proper operational planning should be carried out.

### 5.1.3 Inspection of wire rope, hook and rope pulley

#### 5.1.3.1 Inspection of wire rope

The ropes must be checked by an expert before assembly and checks must be performed at regular intervals in order to detect possible damage or wear and tear at an early stage.

Remove the rope immediately and replace it with a new one if any of the following damage is detected:

- a) Breakage of a strand
- b) Wire breaks
- c) Reduction in the rope diameter by more than 10% of the nominal size
- d) Rope deformation

The replaced rope must comply with the original rope's specification, including the elongation rate of rope length and diameter. The lowering limit switch must be readjusted if a new hoisting rope is used.

Worn rope pulley must be repaired or changed prior to fitting a new hoisting rope. If this is not done, the new hoisting rope will be damaged.

For the detailed information about wire rope inspection and maintenance, please refer to *Maintenance Manual*.

### 5.1.3.2 Inspection of hook

Inspect the hook according to the following items:

- a) Check the hook for distortion, e.g., at the hook jaw.
- b) Check all bolts and screws, and ensure all cotter pins are complete and open.
- c) Check that the rotary connection of the hook can move easily, and the clearance is not too large.
- d) Check the easy rotation of hook: Rotate the hook by hand. If it is stiff, it indicates that the bearing has been damaged.
- e) Check safety catch for completeness and functional work.
- f) Check the hook for corrosion and wear.

### 5.1.3.3 Inspection of rope pulley

Inspect rope pulley according to the following items:

- a) Check rope pulley for damage and cracks.
- b) If rope pulleys have been hit during crane operation (for example on buildings) or if they were subjected to other stress factors, they must be then extensively checked for damage or cracks.
- c) Check for wear on the rope groove. Replace the pulley if the rope groove has been worn down more than 1/4 of the rope diameter.
- d) If any damage or cracks are found, then the rope pulley must be replaced immediately. If this is not observed, there is great danger of causing a serious accident!
- e) Check rope pulley for tight fit. Loose and shaken rope pulley indicates that the bearing and bearing bush are damaged.

### 5.1.3.4 Raising and lowering boom

Before raising or lowering a boom combination, ensure that the following prerequisites are met:

- a) The crane is properly supported and leveled.
- b) The counterweight plates have been attached on slewing table according to requirements.
- c) All limit switches have been correctly set and are fully operational.
- d) The main boom and fixed jib have been attached in accordance with the *Lifting Capacity Chart* and *Operator's Manual*.
- e) All pinned connections have been secured.
- f) There are no loose components on the main boom or fixed jib.
- g) In winter, the main boom and associated parts (limit switches and solar lamp etc.) must be kept free of ice and snow.



Incorrectly fitted or faulty limit switches and falling parts (bolts, retaining spring, ice etc.) can cause injury.

## 5.2 Installation of crane body

### 5.2.1 Transportation modes

Total weight of the crane is 41.3t (with fully configurations). The crane does not need disassembly for transportation. Its transportation mode is as shown in Figure 5-1.

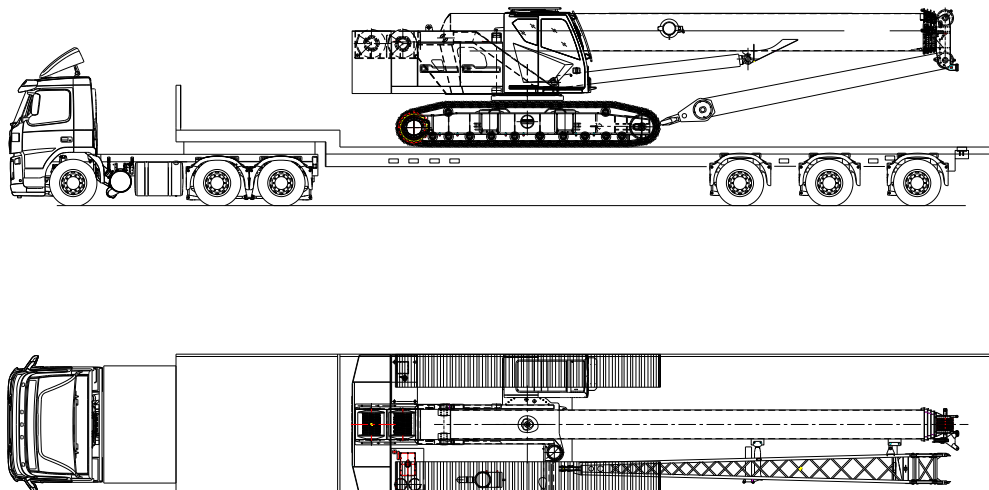

Figure 5-1 Transportation mode

### 5.2.2 Loading of crane body

Check ground surface condition of the loading area. Check fully the crane body for abnormality. Load the crane body according to the working process and safety rules. Clarify personnel responsibilities.

Load the crane body in following steps:

- a) Construct a low slope of approx. 8 degrees using an auxiliary ladder stand of the trailer or sleepers. Press down the locking switch of the superstructure locking device to lock up the slewing mechanism. Retract the two crawlers fully and fix their position.

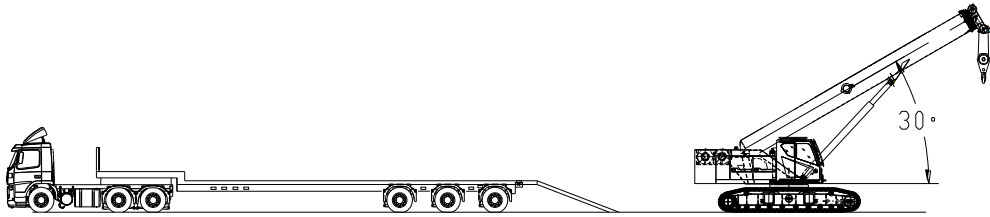

- b) Derrick the boom up to an angle of approx.  $30^{\circ}$ . Spool up the main and auxiliary hooks to their highest positions. Reverse the crane onto the slope at a low speed, and drive it onto the trailer.

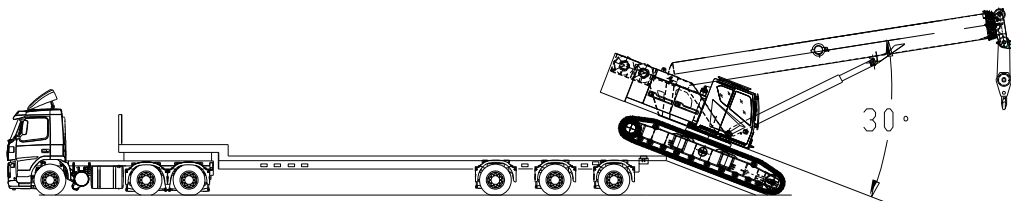

- c) When the rear center of the crawlers reaches top of the slope, reverse further at a low speed to slowly tilt the crane to its horizontal position. Then reverse the crane to its transportation position on the trailer.

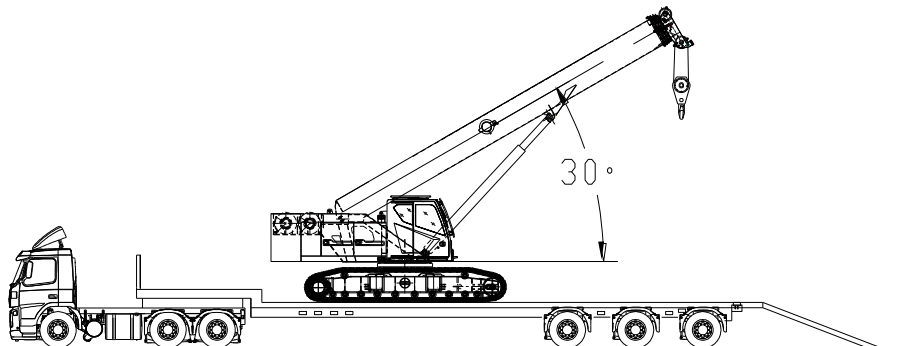

- d) Derrick the boom down to its lowest position when the crane body is properly situated. Fasten the main and auxiliary hooks with a hoisting rope.

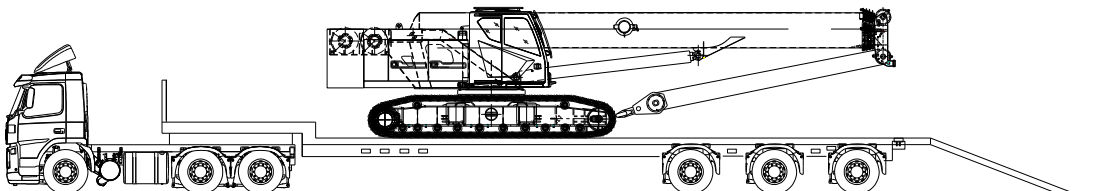

**Figure 5-2 Loading of the crane body**

### 5.2.3 Unloading of crane body

Select proper ground before unloading the crane body. The ground on the jobsite should be firm and flat, and it should be large enough for trailer traveling and auxiliary crane operation.

Make a complete inspection for the crane body before unloading. All operators should be familiar with operating procedures and safety regulations and clear about their areas of responsibility before operation.

Specific unloading procedures are shown as follows:

- a) Check ground surface condition of the unloading area. Keep engine speed at 1000rpm and press down the slewing table locking device to lock up the superstructure. Construct a low slope of approx. 8 degrees using an auxiliary ladder stand of the trailer or sleepers.

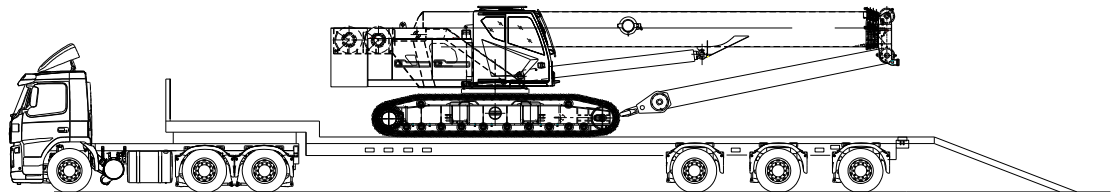

- b) Remove the device fixing the main and auxiliary hooks. Spool them to their highest position and derrick up the boom to an angle of 30 degrees. Drive the crane to the end of the trailer.

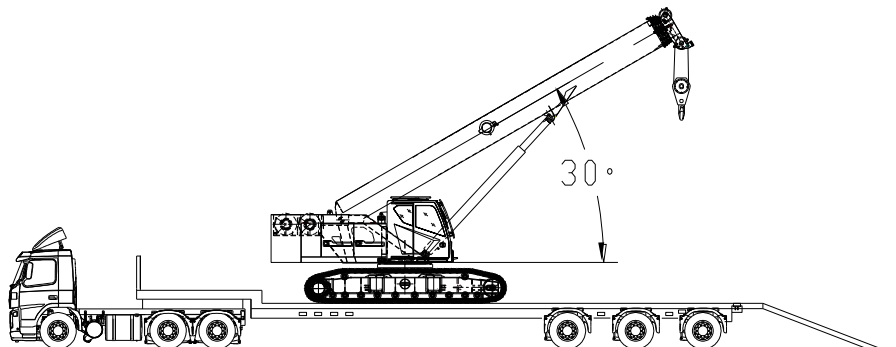

- c) When the center of the crawlers reaches the beginning of the slope, drive the crane at a very low speed onto the slope and then onto the ground.

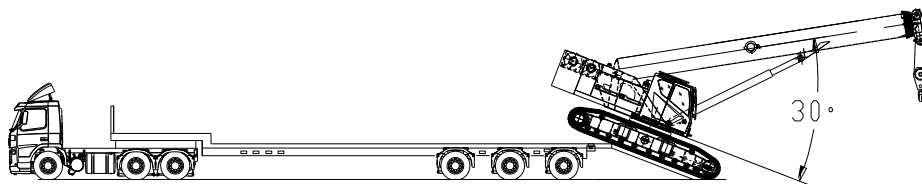

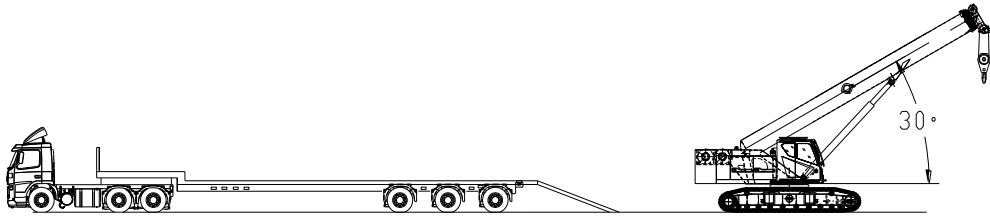

Figure 5-3 Unloading of the crane body

**! WARNING**

- (1) Before transportation, retract the crawler carriers, lay down the boom onto its driving position, and finally lock the slewing mechanism by slewing fixing pin.
- (2) When you drive the main crane body off or onto the low-loader, a steel plate (with an inclination less than or equal to  $8^\circ$  to the ground) should be used to connect the low-loader and the ground. The angle of main boom pivot section should be less than  $30^\circ$  in order to protect the crane against overturning. During this period, the drive sprocket is at the back of the crane, and the driven sprocket is in the front of the crane.
- (3) The crawlers must be retracted during the unloading process, and the boom angle cannot exceed  $30^\circ$ . Slewing is prohibited during loading/unloading of the crane body, otherwise crane tipping over and injuries may be caused.

## 5.2.4 Jib installation (optional)

One lattice jib section is optional for this crane. It is secured on the right side of the main boom through removable pins.

### 5.2.4.1 Assembly

You can assemble the jib at an angle of  $0^\circ$ ,  $15^\circ$  or  $30^\circ$  to the telescopic boom according to work requirements.

Assemble the jib (Take  $0^\circ$  angle for example.).

- a) Extend the outriggers and make the crane level with the level gauge.
- b) Retract the boom fully.
- c) Move the boom to the side or rear of the crane and position it to  $-1.5^\circ$ .

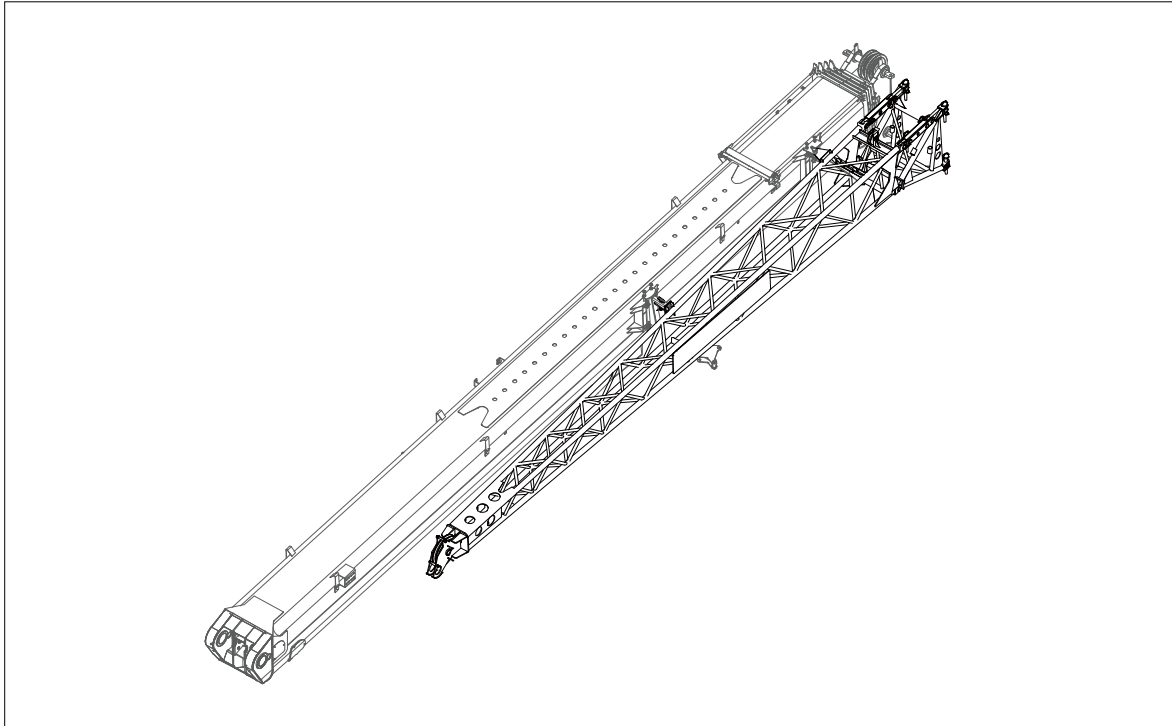

**Figure 5-4 Jib assembly**

- d) Remove the limiting bolt. Extend the bracket and install the removed bolt. See Figure 5-5.

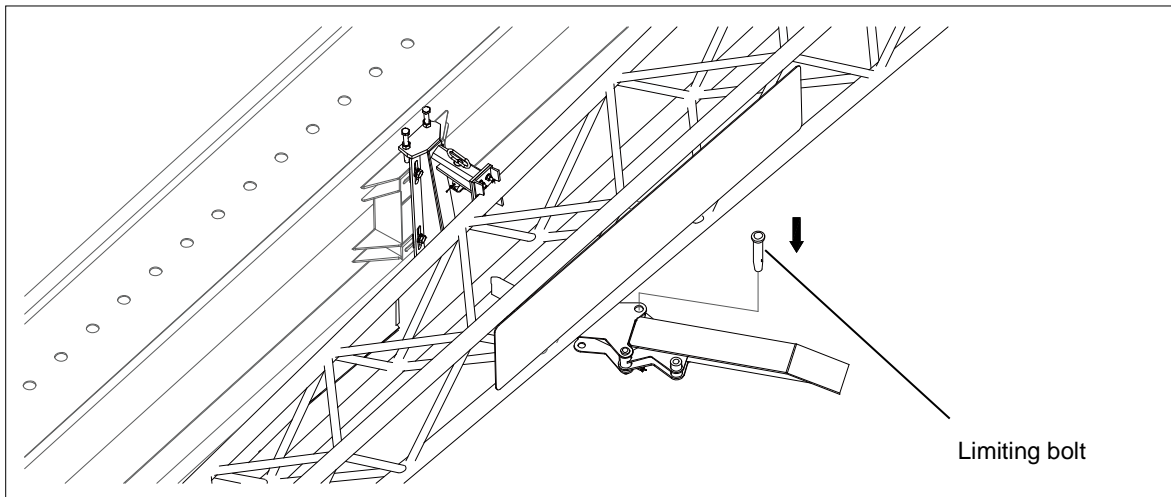

**Figure 5-5 Extend the bracket**

- e) Remove the pin I. See Figure 5-6.

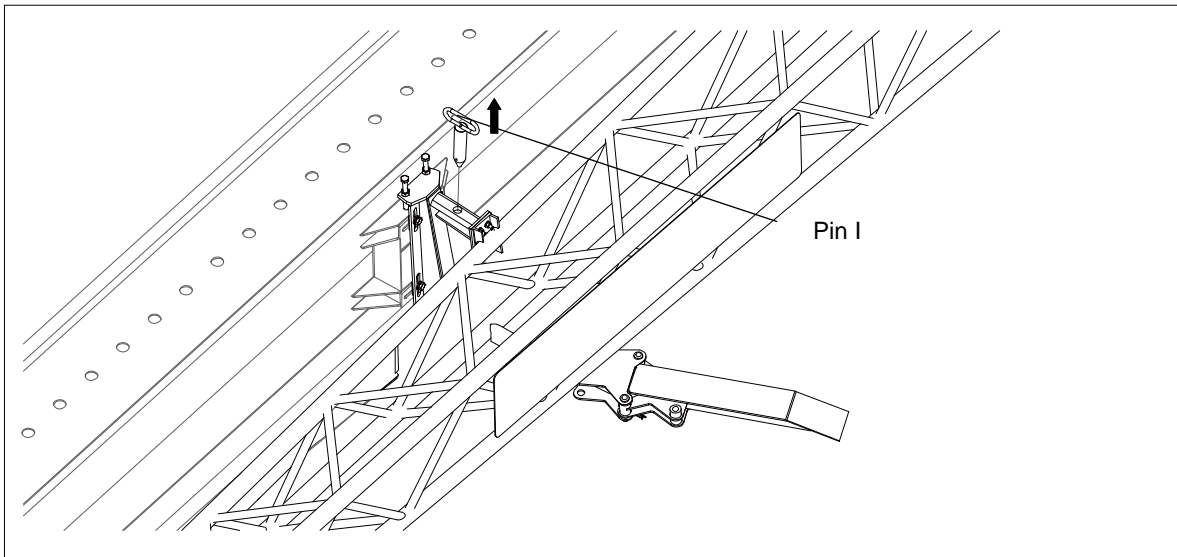

**Figure 5-6 Pin I removal**

- f) Move front of the jib away from the main boom (jib pivots at pin II). See Figure 5-7.

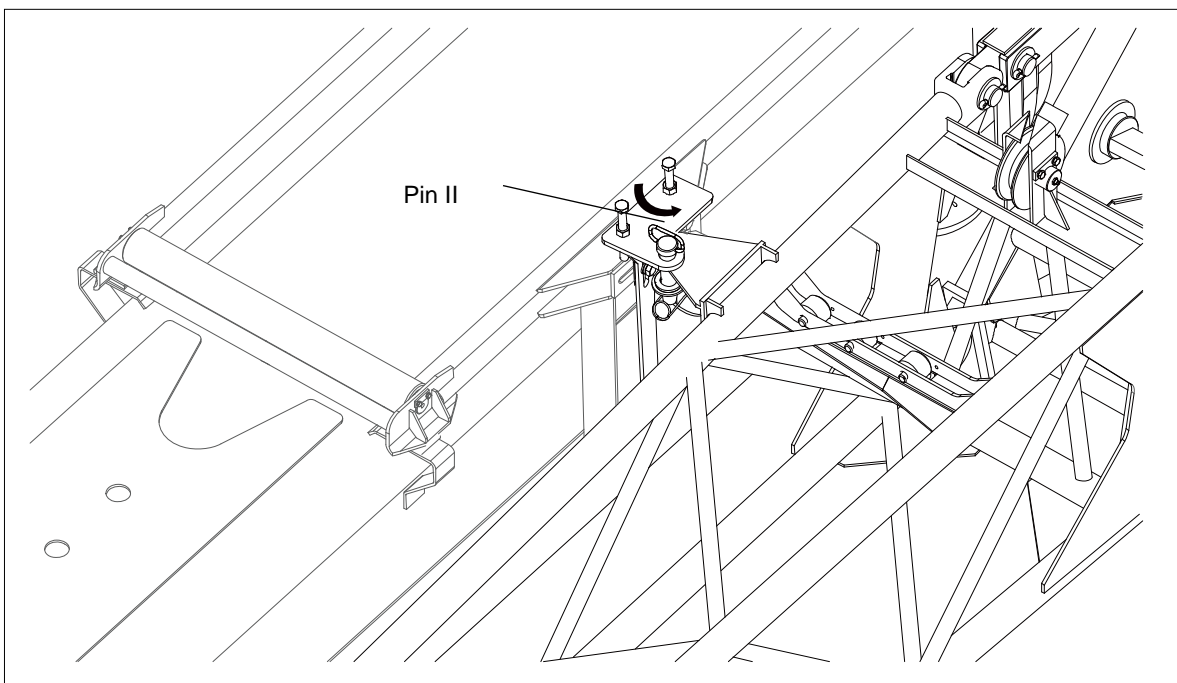

**Figure 5-7 Move front of the jib away from the main boom**

- g) Align the end of the jib with the connection points on the end of the boom. Install pin III and the retaining clip. See Figure 5-8.

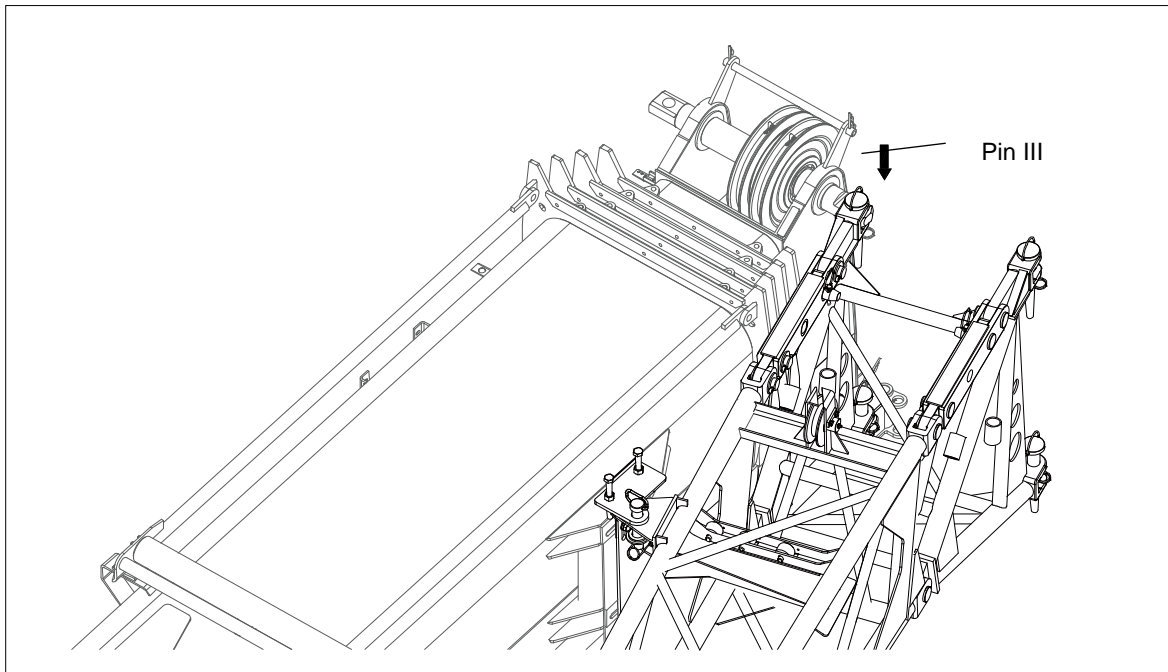

**Figure 5-8 Pin III Installation**

- h) Remove the pin II. See Figure 5-9.

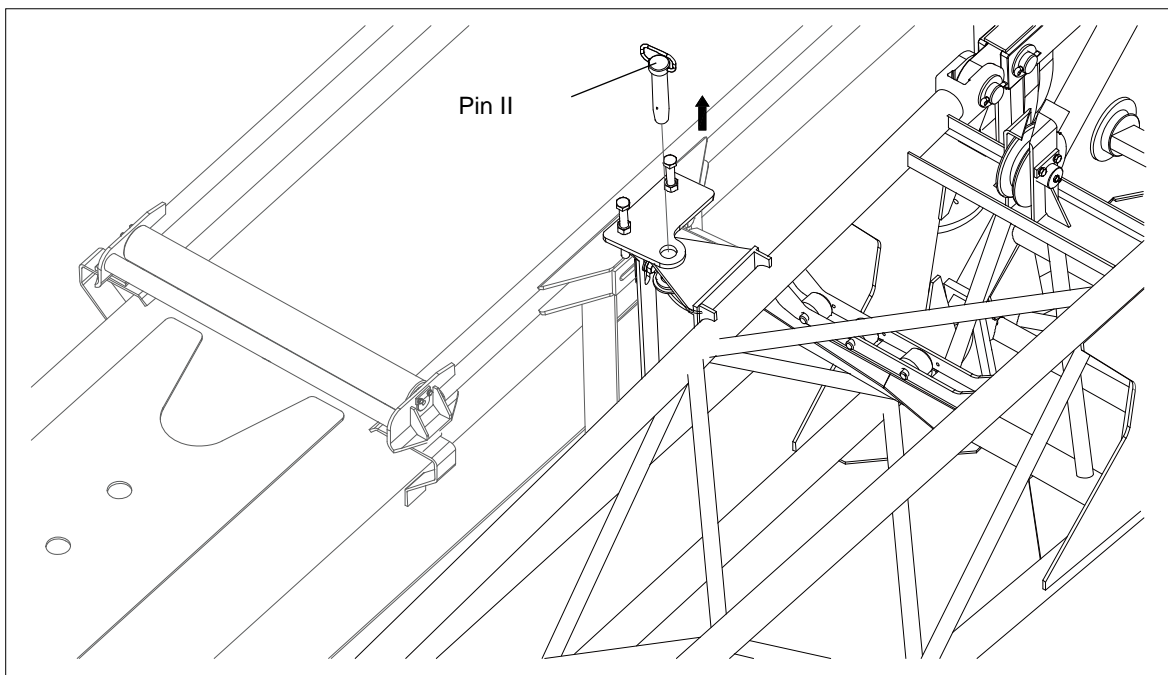

**Figure 5-9 Pin II removal**

- i) Move the jib (pivots on pin III) to the front of the main boom. See Figure 5-10.

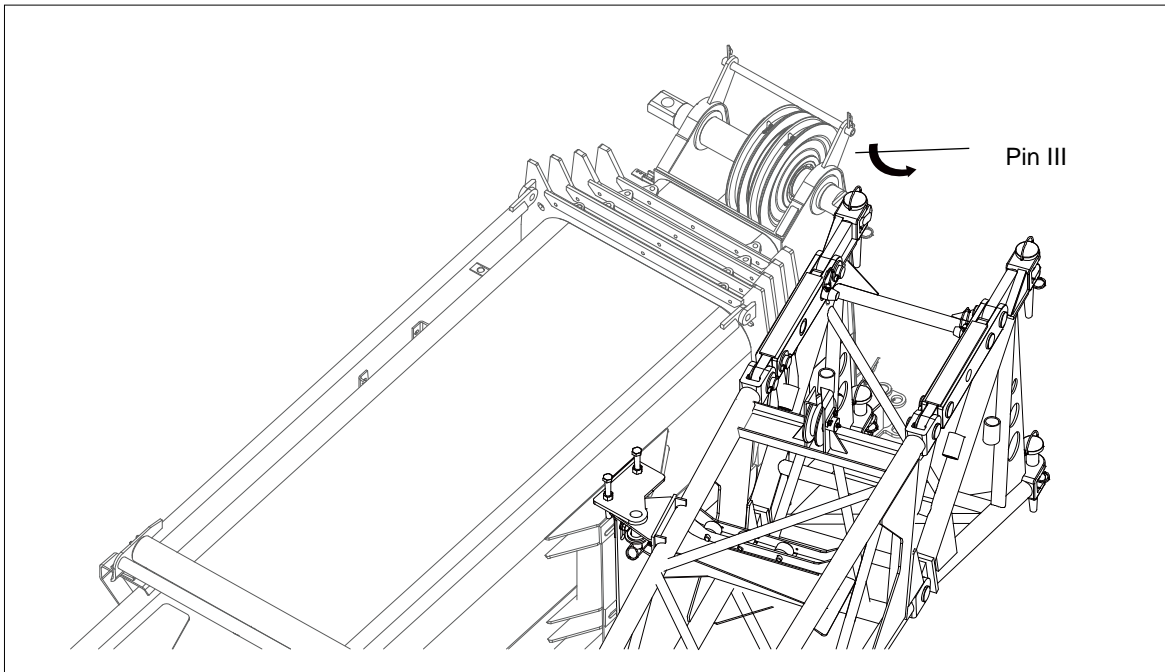

**Figure 5-10 Move the jib to the front of the main boom**

- j) Align the end of the jib with connection points on the main boom. Install the pin IV and the retaining clip. See Figure 5-11.

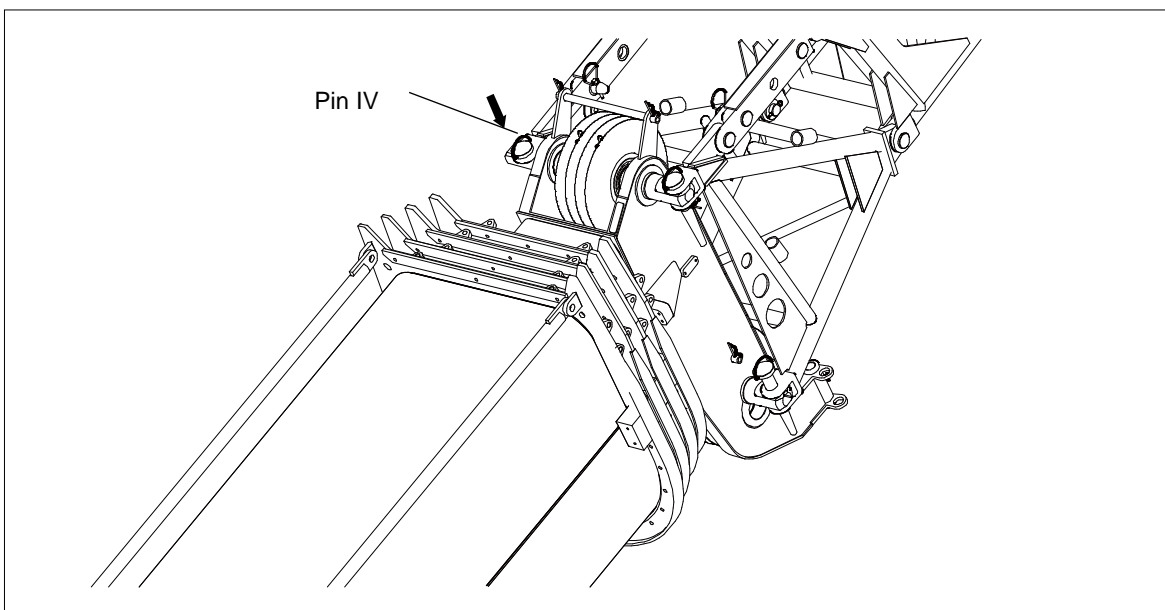

**Figure 5-11 Pin IV installation**

- k) Reeve the wire rope from the auxiliary winch through the end of the jib. Install the auxiliary hook and the hoisting limit switch.



**Do not stand under the jib during the swing operation!**

**The jib and other components – due to an assembly error – can fall down and cause fatal injuries.**

#### 5.2.4.2 Angle settings

The way of changing the angle from 0° to 15° or 30°:

- a) Take out the auxiliary hook from the hook holder.
- b) Deflect the control lever 2 to reel off the auxiliary hoist rope for 2 m to 3 m at low speed.
- c) Change angle to 15° or 30°:
  - 1) Remove the pin and retaining clip from the pull bracket of adapter at jib end.
  - 2) Derrick the boom up slowly until the long groove of adjusting plate is supported.

See Figure 5-12.

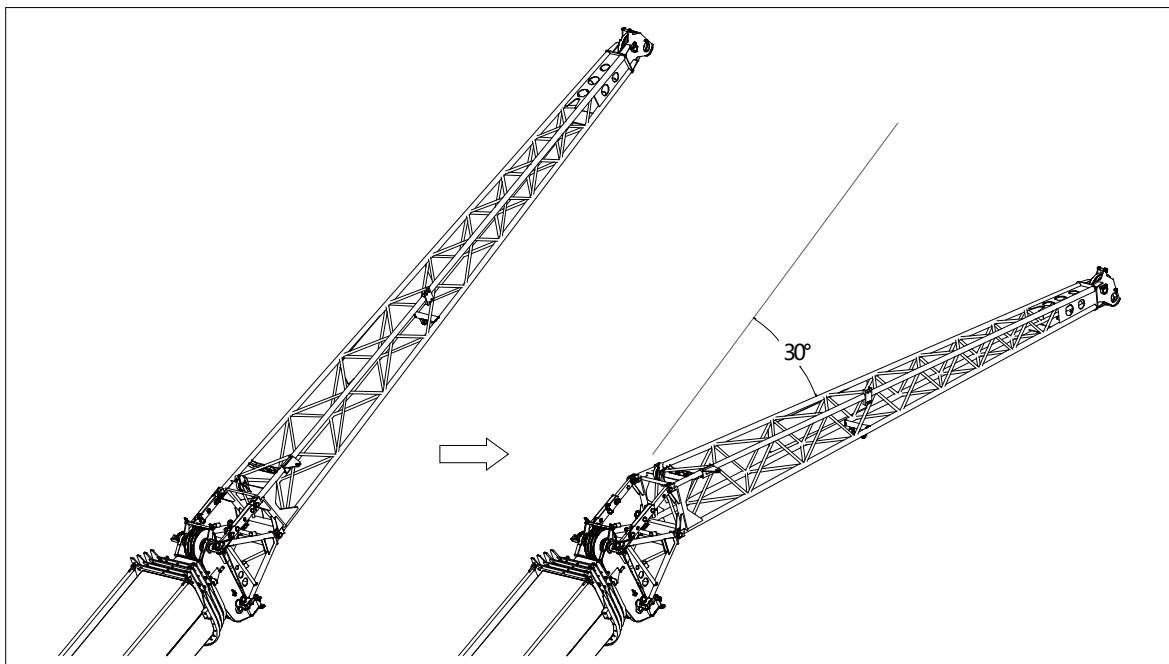

Figure 5-12 Angle positions

### 5.2.4.3 Disassembly

After you complete the jib operation, disassemble the jib in reverse order of the assemble steps.

#### CAUTION

1. Ensure that there is no obstacle or unconcerned personnel within the slewing range of the jib, as shown in Figure 5-13.

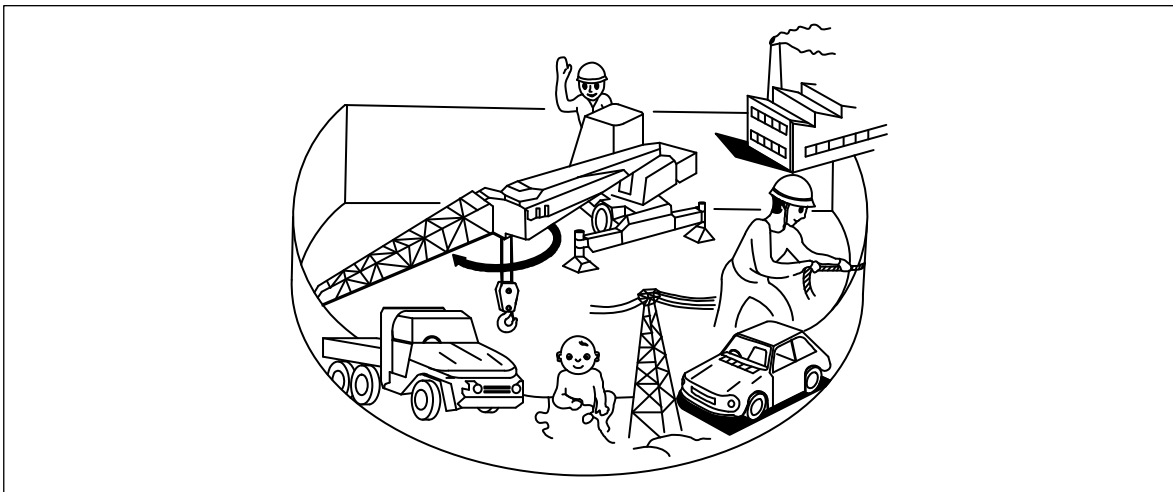
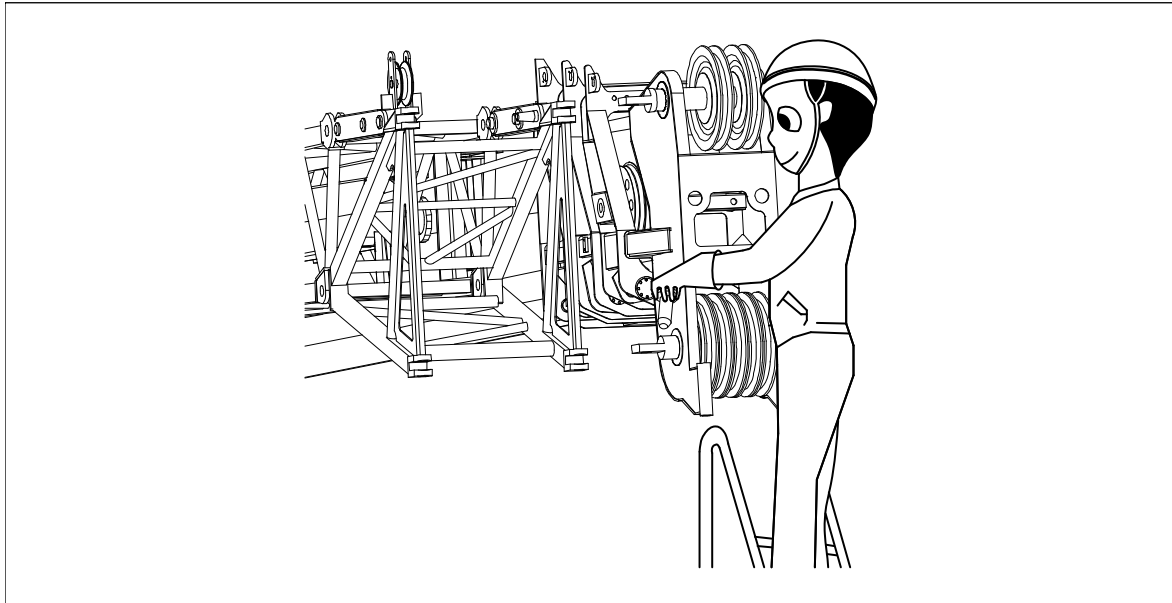

Figure 5-13 Confirmation within the jib's slewing range

2. Assembly and disassembly of the jib should be conducted over the front working area of the crane;
3. Do not operate or drive the crane after the retaining pins for securing the jib are removed from the side of the main boom, otherwise the jib may fall down;
4. When the jib is used for a lift operation, turn the high/low speed pre-selection switch of the auxiliary winch from OFF to "High/low" position;
5. Before assembling the jib, slew the main boom to its front working area and derrick it down to an angle of  $-1.5^{\circ}$ . Use a stair or other working-at-height equipment during collecting the jib to ensure work safety, as shown in Figure 5-14.



**Figure 5-14 Use stairs or other working-at-height equipment**

**6. Operate slowly when collecting and storing the jib;**

**7. Remove and store the auxiliary hook according to hand signals from an instructor.**

### 5.2.5 Rooster sheave

The components of the rooster sheave are as follows:

- Bracket
- Sheave spindle
- Sheave
- Pins.

When it is not necessary to use the rooster sheave, make sure that it is attached to the side of the boom.

When the crane is to lift a light load, use the rooster sheave. This is the most efficient way to move a lighter object.

#### 5.2.5.1 Assembly

- a) Retract the boom fully.
- b) Move the boom over sides and rear and set the boom to the  $-1.5^{\circ}$  position.
- c) Remove the securing pin and move the bracket to the front of the boom. Align the connection points. Install the connecting pin. See Figure 5-15.
- d) Reeve the auxiliary hoist rope through the upper rope pulley and the rooster sheave. Install the auxiliary hook and the hoisting limit switch. Make sure that all connections are tight.

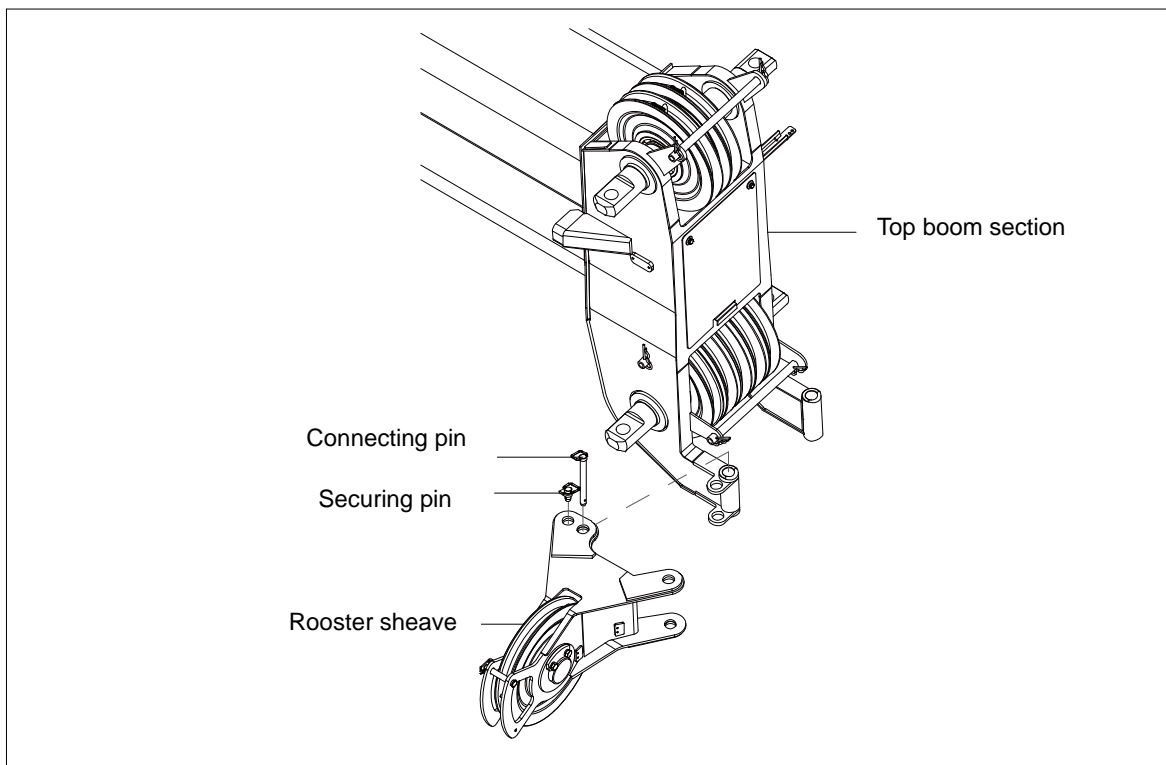

Figure 5-15 Rooster sheave assembly

### 5.2.5.2 Dismantling

When it is not necessary to use the rooster sheave, make sure that it is attached to the side of the boom. Disassemble it in the reverse order of the assemble procedure.

#### CAUTION

1. Before using the rooster sheave for a lift operation, make sure that the jib is folded and stored securely. Never use the rooster sheave when the jib is still erected with the main boom, as shown in Figure 5-16.

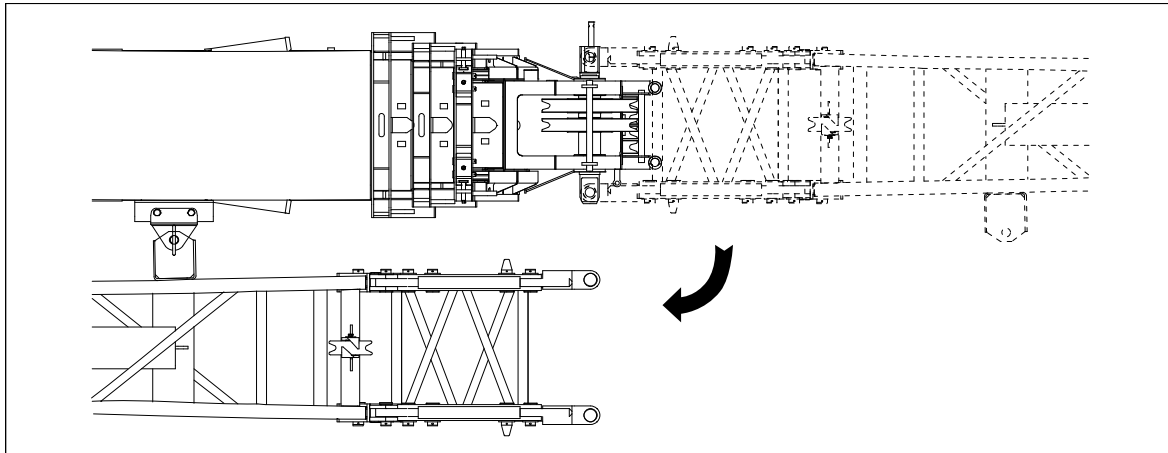

**Figure 5-16 Disassembling the jib**

**2. Installing and disassembling of the auxiliary hook should be conducted according to signals given by an instructor.**

### 5.2.6 Assembly of crawler carriers

- a) Set the carrier body at the specified position. Pull out pin 1 (4 in total) show in Figure 5-17 and place the sliding beam of vertical outrigger to be perpendicular to the carrier. Remove the chuckle plate 2 (4 in total) from the carrier and place it to position as shown in the figure below.
- b) Pull out pin 3 (4 in total) from Position A. Lock tight these pins again into position B of the anchoring rod until the carrier is fully extended and
- c) Start the engine and turn on the horizontal cylinder pre-selection switch. Rotate the horizontal cylinder extending switch to the “Extend” position, then the left and right carriers will slowly be extended out.
- d) Manually push in the pinning mechanism in right front of the chassis frame to ensure that the travelling motor is under working status.

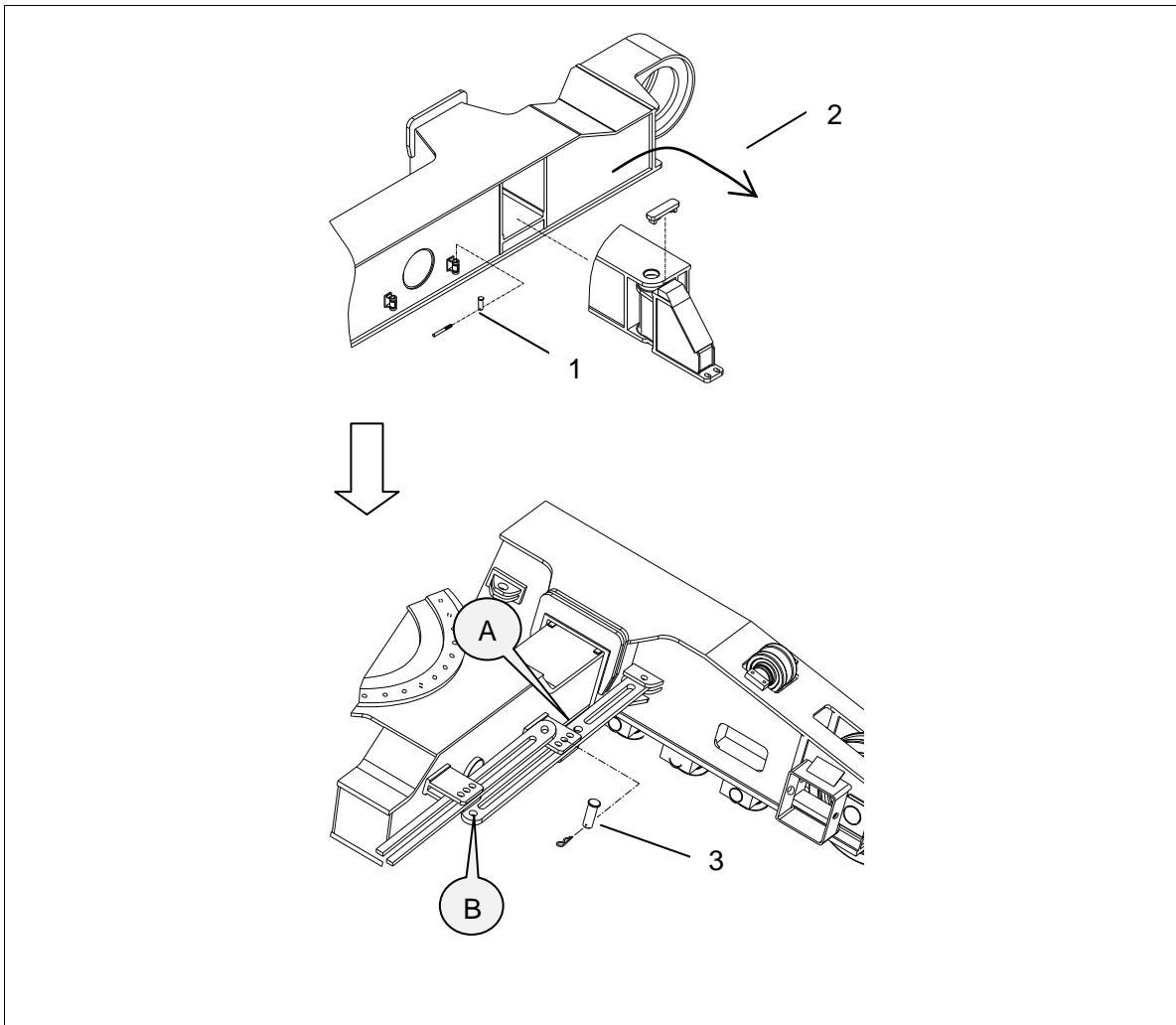

Figure 5-17 Preparation before crawler carrier extension

**! WARNING**

No lift operation shall be done before the crawler carriers are fully extended!

## 5.3 Transport means and requirements for transportation and storage

### 5.3.1 Transport means and requirements for transportation

- a) This crane can be transported in whole, without the need of disassembly, on a truck, crane or other vehicles for long distance.
- b) During transportation, the crane components are fixed by ropes, with the doors and windows locked up. If necessary, take preventive measures against collision, rain and slipping.
- c) The crawler crane should be dismembered and transported in accordance with the permissible load carrying capacity of transport vehicle, the weight, and the local traffic laws and regulations. The transport vehicle is forbidden to be overloaded.
- d) Before transportation, all component should be fixed to prevent them from jostling and sliding.
- e) To understand the detailed transport means, please consult our company.

### 5.3.2 Requirements for storage

If the crane is not put into use for a long time (over 6 months), take the following protective measures.

- a) Wipe off the dust and oil dirt to keep the crane clean.
- b) Retract all the piston rods of the cylinders completely.
- c) Put the battery in a dry and ventilating place and charge it periodically.
- d) Grease the surfaces of all exposed components to prevent them from corroding.
- e) Clean the wire ropes and grease them again with ZG-3 graphite calcium base grease.
- f) Store the crane in a garage. If the crane is placed in the open air, it must be covered up with water-proof cloth to prevent it from corroding, and in winter antifreeze measure should be taken.
- g) Start the crane once a month and run all mechanisms without load to check whether they are in good condition.
- h) Assign a person responsible for the completeness of the crane so that it can be put into operation at any time.



**The crane that has been stored for a long time should be inspected completely before using it again.**